

Fall 1-31-2015

## Fem of electrospinning compared to inkjet printing model

Maikel Ghaly  
*New Jersey Institute of Technology*

Follow this and additional works at: <https://digitalcommons.njit.edu/theses>



Part of the [Biomedical Engineering and Bioengineering Commons](#)

---

### Recommended Citation

Ghaly, Maikel, "Fem of electrospinning compared to inkjet printing model" (2015). *Theses*. 216.  
<https://digitalcommons.njit.edu/theses/216>

This Thesis is brought to you for free and open access by the Electronic Theses and Dissertations at Digital Commons @ NJIT. It has been accepted for inclusion in Theses by an authorized administrator of Digital Commons @ NJIT. For more information, please contact [digitalcommons@njit.edu](mailto:digitalcommons@njit.edu).

## **Copyright Warning & Restrictions**

The copyright law of the United States (Title 17, United States Code) governs the making of photocopies or other reproductions of copyrighted material.

Under certain conditions specified in the law, libraries and archives are authorized to furnish a photocopy or other reproduction. One of these specified conditions is that the photocopy or reproduction is not to be “used for any purpose other than private study, scholarship, or research.” If a user makes a request for, or later uses, a photocopy or reproduction for purposes in excess of “fair use” that user may be liable for copyright infringement,

This institution reserves the right to refuse to accept a copying order if, in its judgment, fulfillment of the order would involve violation of copyright law.

**Please Note: The author retains the copyright while the New Jersey Institute of Technology reserves the right to distribute this thesis or dissertation**

Printing note: If you do not wish to print this page, then select “Pages from: first page # to: last page #” on the print dialog screen

The Van Houten library has removed some of the personal information and all signatures from the approval page and biographical sketches of theses and dissertations in order to protect the identity of NJIT graduates and faculty.

## **ABSTRACT**

### **FEM OF ELECTROSPINNING COMPARED TO INKJET PRINTING**

**by  
Maikel Ghaly**

Electrospinning is a process that uses electrostatic forces to produce nanofibers, or fibers in the nano scale. Nanofibers are widely used in many fields like drug delivery and tissue engineering. Nowadays, it is gaining much attention in the research community as an advantageous process. However, there are many parameters that control nanofiber formation. This research intends to develop a model of electrospinning on the basis of an inkjet printer technique by using a computer aided simulation (COMSOL). Inkjet printing is a technique that delivers small volumes at high repetitions which can be transported by electrostatic forces through the air onto their intended target. The similarity of electrospinning and inkjet printing can be seen in the method of delivering the solution whether it is ink or a polymer to its intended target. Inkjet printing technique is controlled and reproducible while electrospinning has a certain level of control which creates variability from lot-to-lot. Taking the combined parameters of inkjet printing and electrospinning can help create more controlled experiments and reproducible results.

**FEM OF ELECTROSPINNING COMPARED TO INKJET PRINTING MODEL**

**by  
Maikel Ghaly**

**A Thesis  
Submitted to the Faculty of  
New Jersey Institute of Technology  
in Partial Fulfillment of the Requirements for the Degree of  
Master of Science in Biomedical Engineering**

**Department of Biomedical Engineering**

**January 2015**

Blank Page

**APPROVAL PAGE**

**FEM OF ELECTROSPINNING COMPARED TO INKJET PRINTING**

**MaikelGhaly**

---

Dr. Michael Jaffe, Thesis Advisor Date  
Research Professor of Biomedical Engineering, NJIT

---

Dr. TreenaArinzeh, Committee Member Date  
Professor of Biomedical Engineering, NJIT

---

Dr. Bryan Pfister, Committee Member Date  
Associate Professor of Biomedical Engineering, NJIT

## **BIOGRAPHICAL SKETCH**

**Author:** Maikel Ghaly  
**Degree:** Masters of Science  
**Date:** January 2015

### **Undergraduate and Graduate Education:**

- Master of Science in Biomedical Engineering,  
New Jersey Institute of Technology, Newark, NJ, 2015
- Bachelor of Science in Biomedical Engineering,  
New Jersey Institute of Technology, Newark, NJ, 2014

**Major:** Biomedical Engineering



I would like to dedicate this thesis to my mother, Gehan Youssef, and my sister, Sandy Ghaly, who have stood by me. I am also thankful to all my professors and friends who have made it possible for me to reach this point in my life.

## ACKNOWLEDGMENT

I would like to thank Dr. Michael Jaffe for helping me through my thesis and being there for me when I needed advice not only about the thesis but also about life. I am grateful for Dr. Bryan Pfister and Dr. Treena Arinzeh for being a part of my committee and taking interest in my thesis. I appreciate Dr. George Collins, Dr. Bruno Mantilla, and Dr. Joel Schesser for being my mentors throughout my college career.

Lastly, I would like to thank my family Samy Ghaly, Gehan Youssef, Sandy Ghaly and Ramsis Barsoum Hanna for helping me through this journey.

## TABLE OF CONTENTS

<b>Chapter</b>	<b>Page</b>
1 INTRODUCTION.....	1
1.1 Objective.....	1
1.2 Electrospinning History.....	3
2 BACKGROUND.....	5
2.1 Electrospinning Process.....	5
2.2 Parameters of Electrospinning.....	6
2.3 Electrospinning Applications.....	7
3 INKJET PRINTING.....	10
3.1 Background .....	10
3.2 Inkjet History.....	11
3.3 Parameters that Affect Inkjet Printing.....	12
3.4 Electrospray Process.....	12
3.5 Inkjet Applications.....	15
4 COMSOL MULTIPHYSICS.....	17
4.1 Background.....	17
4.2 Materials and Methods.....	17
5 RESULTS.....	20
5.1 Results of Inkjet Model.....	20
5.2 Refined Methods of Inkjet Model.....	21
5.3 Refined Results of Inkjet Model .....	22
6 DISCUSSION.....	29

**TABLE OF CONTENTS**  
**(Continued)**

6.1 Discussion of Results.....	29
6.2 Future Studies.....	32
6.3 Conclusion.....	33
REFERENCES.....	34

# CHAPTER 1

## INTRODUCTION

### 1.1 Objective

Nanotechnology is the application or procedure of producing materials that are less than 100 nanometers in diameter. The multidisciplinary system of nanotechnology is a growing and popular field because of its advantages in many different ways and in many fields [14]. Nanotechnology contributes to improving and even revolutionizing, many technology and industry sectors such as drug delivery, materials, electronics, and filtration [1]. All these fields and many more can be aided by the development of nanotechnology. The process of creating nano-materials changes the material's physical, chemical, and mechanical properties which can be valuable depending on its application.

Polymers affect every aspect in our lives such as the plastic bottles we drink out of and the clothes we wear. Polymers are processed by using three fundamental techniques; injection molding, extrusion, and spinning [16]. There are different types of spinning such as melt, dry, wet, and electro. Melt spinning is used for polymers that are melted and then extruded through the spinneret and immediately solidified by cooling. Such materials produced in this manner are nylon and polyester. Dry spinning is another method to create fibers by solidifying the polymer by evaporating the solvent in a stream of inert gas. Wet spinning is the oldest process to create fibers. In this process the fiber is formed by submerging the spinnerets in a chemical bath and as the fibers emerge they precipitate and solidify. All these methods create fibers that are in the micro-scale and use mechanical forces to produce fibers [16].

The last form of fiber-forming process is electrospinning. Electrospinning is an electrostatic method that produces polymer fibers that range from few micrometers in diameter to nanometers. This method can be used for both natural and synthetic polymers and has its advantages over the conventional methods of spinning. The process of electrospinning is unique because of the fact that it can produce nanofibers with some degree of control of the pore size and alignment in non-woven mat structures. These advantages cause electrospinning to gain much attention over the last decade. By creating smaller pore size, it increases the surface area than mechanically spun fibers. Other than a high surface-to-volume ratio, electrospinning also creates malleable fibers and tunable porosity in non-woven mats [16]. Electrospinning is being used in numerous fields, such as tissue scaffolds, filtration, biotechnology, and biomedical engineering.

Understanding the mechanics behind electrospinning will help give more refined and desired outcomes, besides, it will explain how (electrospinning techniques) can be comparable to the ones used in inkjet printing. Just like electrospinning, there are many types of inkjet printing techniques; some use certain signals such as waveforms to eject ink to a target while others use electrostatic forces. The focus of this study is to compare a model of inkjet printing to electrospinning to better help understand how to acquire desired and reproducible outcomes. The inkjet model will be the basis for electrospinning due to the similarity in their parameters.

## 1.2 Electrospinning History

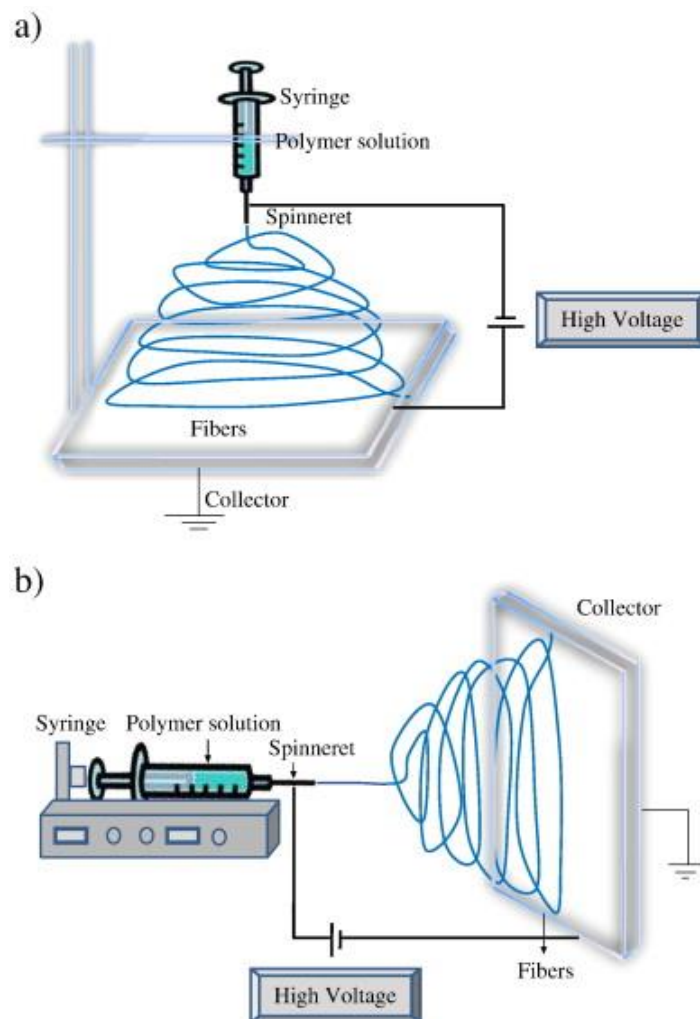
Electrospinning has been around for approximately 80 years. In 1934, Anton Formhals patented his first invention of a process and an apparatus that produces filaments by electric charges. Even though this method was around long before Formhals, it did not gain the recognition until his invention. Formhals was able to create aligned threads however, his method had some disadvantage. One major disadvantage was the fiber did not completely solidify after spinning because of the short distance between spinning and the collector plate. After noticing this, Formhals redesigned his process and added a longer distance to allow for drying time for the fibers, which led to another patent [3] and [4].

This discovery was followed up 30 years later by Geoffrey Taylor who would be known for publishing work about the first phase, or jet initiation phase. Taylor mainly studied how a droplet forms when an electrostatic field is applied. His studies showed that the droplet transforms into a cone when the surface tension is at equilibrium with the electrostatic forces. Once the electrostatic forces exceed the surface tension, the polymer jet is expelled from the apex of the cone [3] and [4].

After Taylor's work, the attention moved towards understanding the relationships between certain parameters such as solution viscosity, flow rate, and the voltage applied. In 1971, Baumgarten began this study and used polyacrylonitrile/dimethylformamide solution. His discovery was made by the help of a high speed camera where he was able to show that a single fiber was being ejected from the pendant droplet. Throughout this study, Baumgarten also noticed that the diameter of the polymer was directly

dependent on solution viscosity as he noticed that higher viscosity gives larger fiber diameter [3] and [4].

A few years later electrospinning was used to fabricate fibrous mats for fields such as tissue engineering. In 1978, Annis and Bornat created electrospun mats for vascular prosthesis. This was one of the earliest attempts to use electrospinning for tissue engineering and would not become widespread until another decade [3].



**Figure 1.1** a) The electrospinning apparatus in vertical orientation.

b) The electrospinning apparatus in horizontal orientation.

Source: [4]



## CHAPTER 2

### BACKGROUND

#### 2.1 Electrospinning Process

The electrospinning process creates a polymer nanofiber which is caused by an elongation when the polymer is exposed to an electrostatic field. The electrostatic forces play an important role because they cause the stretching and thinning of the polymer. The electric potential difference from the syringe to the collector plate ranges from 10 to 60 kilovolts. Because of such a high electric field, the electric forces are applied to the polymeric droplet. The applied voltage is a crucial element that affects nanofiber diameter. The general notion is increasing an applied voltage produces smaller nanofiber diameters [4].

As the forces are applied, there forms a hemispherical droplet at the tip of the syringe. This extends into a cone shape, called Taylor's Cone. This is formed by increasing the voltage supply which causes critical field strength,  $E_{critical}$  that corresponds to a certain voltage;  $V_{critical}$ . The electric pressure overcomes the capillary pressure and collapses the Taylor Cone; simultaneously a liquid jet of polymer is ejected into a jet. After the jet is ejected, there occurs a bending and whipping motion due to the instability of the repulsive Coulomb forces of the surface charges. This whipping motion leads to the elongation and acceleration of the liquid. As the liquid polymer goes through this whipping motion, the area of the polymer increases, which causes 90% of the solvent to evaporate, and a dry polymer is formed [3].

## 2.2 Parameters of Electrospinning

Many parameters such as solution parameters, processing parameters, and ambient parameters, affect the electrospinning process. Solution parameters that can affect electrospinning are viscosity, concentration, molecular weight, and surface tension. Processing parameters include flow rate, needle shape, and collector distance. Lastly, ambient temperatures such as temperature and humidity affect electrospinning [2], [6], and [15].

Concentration is one of the most important parameters that effect fiber morphology. Research and studies have showed that lower concentration causes a continuous jet. Having a higher concentration can cause non-dried fibers and can even inhibit jet ejection completely due to high surface tension. The higher surface tension will overcome the electrostatic forces and polymer will not be ejected. Concentration effect is closely connected to viscosity, rheology, and surface tension which make having an ideal concentration important [2]. It is essential for the electric charges from the electrode to the droplet to be transferred. For this transfer of electric charges to occur, solutions must have minimal electrical conductivity. Solutions with no electrical conductivity cannot be electrospun [14] and [15].

As the flow rate is applied, the high voltage results in the deformation of the Taylor cone, and bring about bead formation of the droplet. Having a higher voltage and flow rate can prevent bead formation but can also lead to scattering of leading fiber and variable fiber diameter. Higher voltage speeds up electrostatic forces which can stop the complete evaporation of solvent; however if the voltage and the flow rate are too low,

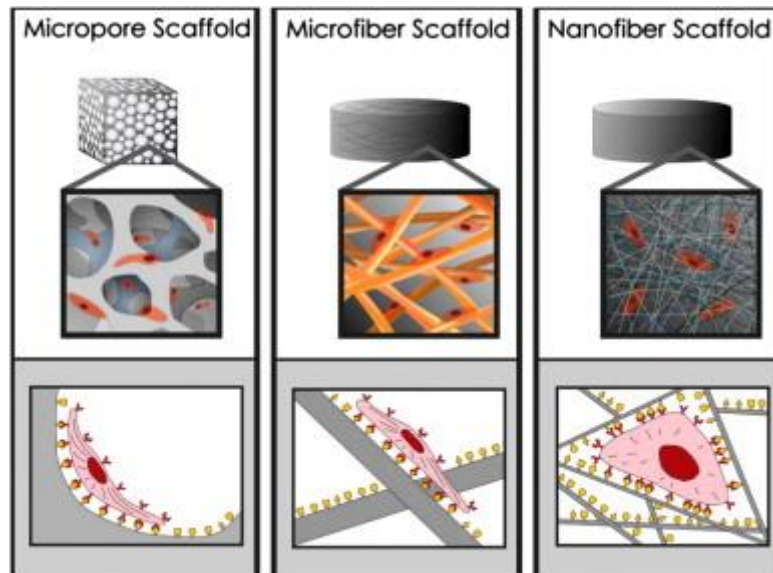
they can hinder the ejection of the polymer [2]. To obtain solid nanofibers and evaporation, the ideal flow rate must match the solution removing rate from the tip [14].

Tip to collector distance is crucial to give polymers enough time to evaporate and dry before reaching the collector plate. The collector plate distance will affect fiber uniformity while the distance varies depending on the concentration and the applied voltage [6]. Collector plates can be used to create uniform aligned fibrous scaffolds. This can be achieved by a rotating cylinder or mandrel. This desired outcome is useful in tissue engineering to imitate collagen fibers [2].

### **2.3 Electrospinning Applications**

Tissue engineering is an interdisciplinary field that associates with regenerative medicine. It is such a broad field that it involves medicine, biology, and engineering. One main attribute that tissue engineering uses is the creation of scaffolds to offer support for cells to recreate extra cellular matrices that can make for the ones which have been destroyed. Electrospinning can help create these scaffolds due to its high surface area which can simulate the extra cellular matrix [15].

Scaffolds must have two main characteristics which are biocompatibility, biodegradability. These requirements can be greatly affected by scaffold architecture. Nanoscale architecture affects cell attachment and proliferation. Cells that bind to nanoscale architecture are more flattened, which causes more protein binding sites to be in contact with the scaffold. The adsorbed protein can change conformation and create additional binding sites.



**Figure 1.2** Nano-fibers created from electrospinning create a higher surface area to volume which is the most suitable for tissue engineering applications.  
Source: [16]

Applications of electrospinning such as tissue engineering scaffolds, wound dressing, and filtration have been thoroughly explored. However, the application of electrospinning for chemotherapy has recently become popular. Using electrospun mats for localized chemotherapy can be a new and innovative solution that can supersede using an old method. Electrospun mats have an advantage over other methods such as hydrogels, because they can lower toxicity and raise drug concentration locally, which works well with solid tumors. Normally, a solid tumor would be treated with a surgical procedure followed by chemotherapy. Local mat therapy can be an alternative option which can limit post-surgery tumor recurrence.

One study done by Liu et al. created Doxorubicin (Dox) nanofibers using PLLA to transport the Dox and then inspected its effectiveness. The results of this study showed that mostly all of the Dox that was infused in the fibers were released and diffused into the tumor. This diffusion led to the inhibition of tumor growth with minimal damage to

other organs. The possibility of using electrospinning can be beneficial to prepare these scaffolds to control drug release. A scaffold can also be used as a barrier while controlling drug delivery.

## **CHAPTER 3**

### **INKJET PRINTING**

#### **3.1 Background**

Inkjet printing is a technique used in the fields of nanotechnology, pharmaceuticals, and bio-chemical for its cost-efficient and multipurposeway. This method was commercialized in the 1970s, and since then, it has been used for the precise delivery for small volumes at high repetition. There are many classes of inkjet printing such as the conventional inkjet which can be drop-on-demand or continuous inkjet and inkjet spray where it is more of a spray than of liquid. These techniques are different but still have the same outcome which is a uniform droplet, depending on the application [5].

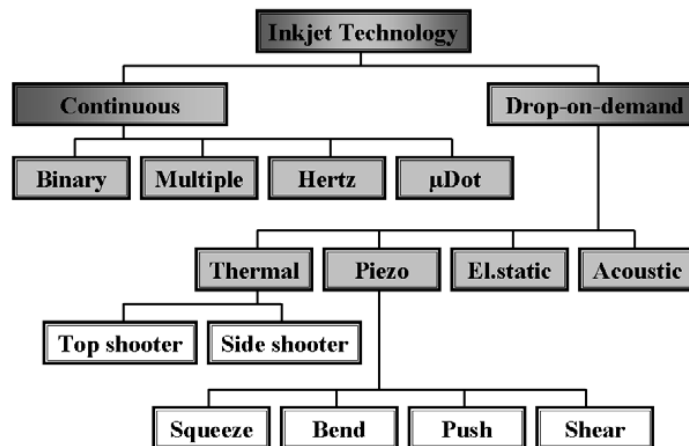
Drop-on-demand (DoD) inkjet produces distinct droplets in response to a certain signal such as a waveform. This specific technique is used to create 15-55  $\mu\text{m}$  diameter droplets. Unlike DoD, continuous inkjet (CIJ) printing is an unbroken stream of liquid that is broken up by repetitive variation. CIJ printing creates 80-100  $\mu\text{m}$  droplets. To accurately place these droplets, electrostatic charging or deflection is used [5].

Another method of inkjet printing is the electrospray technique, which is also known as the electrohydrodynamic printing. This method closely relates to electrospinning and can produce small droplets from a large nozzle. This method uses, just as electrospinning, electrostatic forces to eject fluid.

### 3.2 Inkjet History

Inkjet technology started in the late 1950's for color document production. The first inkjet device that used electrostatic forces was invented by William Thomson in 1858. This device was used for telegraph messages that provided a continuous stream of ink onto moving paper. Physicist Joseph Plateau is considered the most important founder of inkjet technology, who, in 1865, proportioned the ratio of jet diameter to drop size [7].

Finally, during the 19<sup>th</sup> century inkjet technology became more advanced. In 1931 piezoelectric material was used, but still took decades before it was used in a working device. A continuous inkjet was introduced in the 1960s by R.G. Sweet. He showed that applying pressure to an opening of the ink would break into droplets of uniform size and space [7].



**Figure 3.3** Tree diagram of different types of inkjet technologies.  
Source: [7]

### 3.3 Parameters That Affect Inkjet Printing

Like electrospinning, inkjet printing has several parameters that affect the inkjet printing process. Several parameters that characterize ejection procedure can be velocity, volume, density, and shape. Velocity or frequency is very important aspect in both electrospinning and inkjet printing. A low velocity in inkjet printing can increase positioning errors, while a higher velocity will cause splashing-on impact. The velocity and volume should fall between certain ranges to decrease irregularities. To achieve the desired quality and consistency, droplets should be spherical without dragging tails [8].

The materials used in the field of printing, in this case the ink, have an effect on ejection. Material properties that effect droplets are density, viscosity, and surface tension. These can be classified by the reciprocal of Ohnesorge number, where  $\eta$  is viscosity,  $\rho$  is density,  $\gamma$  is surface tension, and  $L$  is diameter. Equation (3.1) shows that stable droplets form when  $Z$  is between 1 and 10 [8].

$$Z = \frac{\eta}{\sqrt{(\rho\gamma L)}} \quad (3.1)$$

### 3.4 Electro spray Process

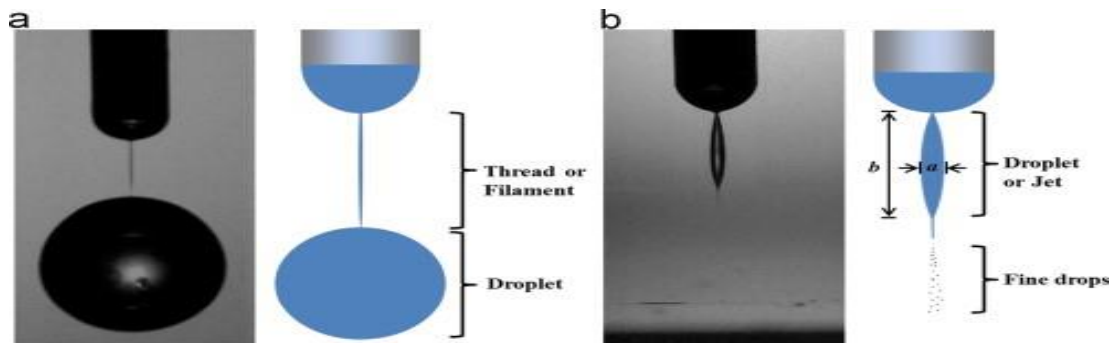
Electrospray or electrohydrodynamic (EHD) inkjets produce micro- and nano-sized droplets, which are created when an electrostatic field is present between the nozzle and the target. Due to the fact that EHD creates small droplets, it is widely used in



regenerative medicine and drug delivery. Also, the inkjet printing technique is noncontact printing which does not damage the substrate or target.

The production of droplets or spray by using electric field dates back to Gilbert Rayleigh who determined the stability of a single charged droplet. While Taylor identified the conical angle of 49.3 degrees for electrospinning where the fluid would be ejected under electrostatic forces, Notz and Basaran numerically conducted finite element analysis to determine the exact moment when a charged droplet will separate or "pinch-off" from the continuous fluid. Other work shows the viscous effect, ratio of the size of the droplet, and the Coulombic stability effect pinch-off time.

Pinch-off behavior is important to understand because it influences the topology of the electrified droplet. As pinch-off approaches, the thread becomes small that Reynolds number approaches zero and the viscous forces become dominant.



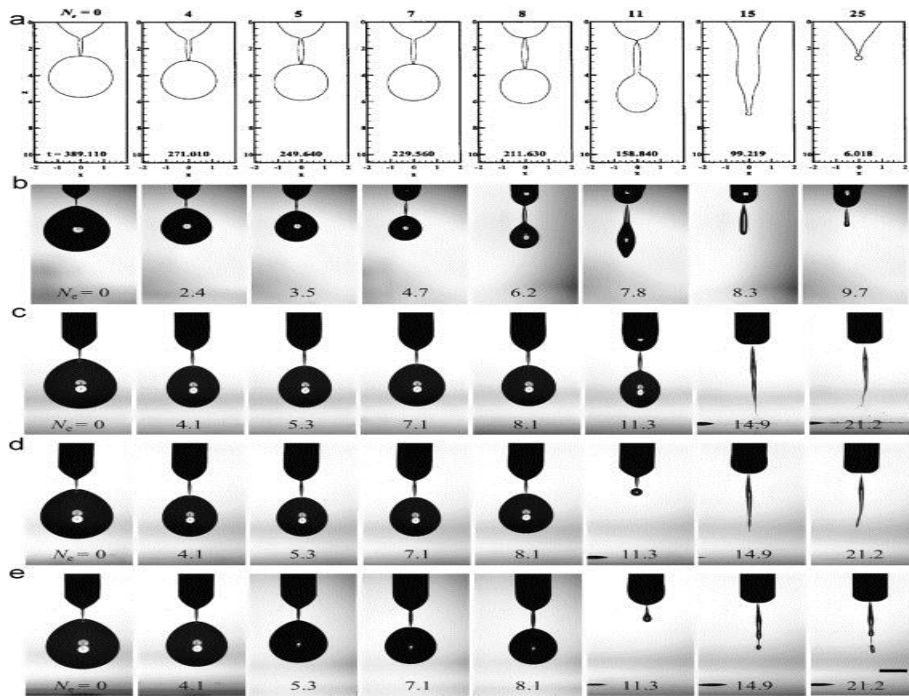
**Figure 3.5** Schematic of different inkjet pinch-off behaviors.

Source: [13]

Viscosity and charge level affect the pinch-off. Research shows that the charge level is defined as:

$$Ne = \epsilon_0 V^2 / (2R\sigma) \quad (3.2)$$

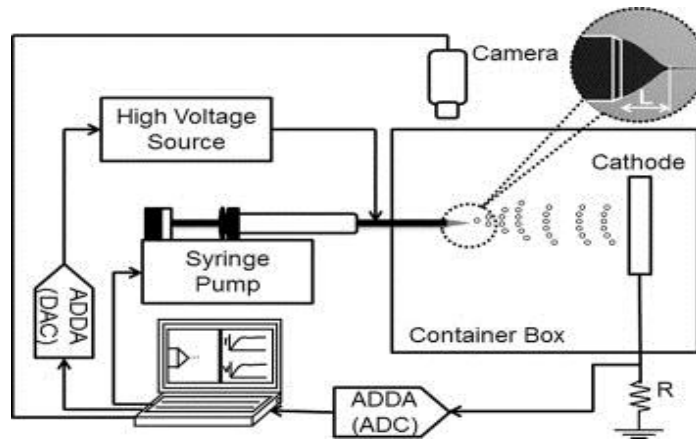
$\epsilon_0$ ,  $V$ ,  $R$ , and  $\sigma$  are electric permittivity of free space, applied voltage, capillary radius, and surface tension.



**Figure 3.5** Different charging levels to show pinch-off behaviors.

Source: [13]

Electrical conductivity, charge level, and surface tensions affect EHD inkjet.



**Figure 3.4** Schematic of electrospaying.  
Source: [5]

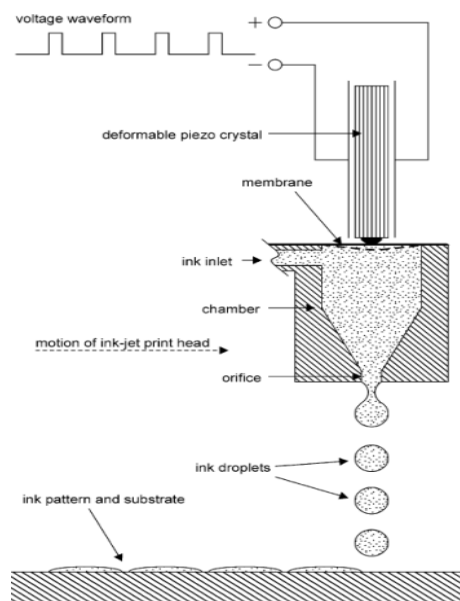
### 3.5 Inkjet Applications

Inkjet printing may not be thought of as a technique used in biomedical engineering but it is an inexpensive procedure to create controlled droplets with certain size and location. For example, the study of neurons in a controlled environment outside of the body requires patterned cell cultures to investigate smaller isolated networks. Previous work for patterned neuron cultures used small islands of adhesive protein achieved by airbrush to generate tiny droplets. However, this technique, like contact masks and microstamping, is based from pre-existing patterns and limit possible experimentation [10].

To overcome this problem, inkjet technique is used to create patterned neuron cultures. Instead of normal inkjet printing used for printing ink onto paper, it is used to deliver accurate and precise droplets of biologically- active materials onto coverslips. The advantage of inkjet printing technique is the ability to create any pattern with precision by changing the waveform. Inkjet printing technique is also advantageous because it can deposit multilayers of materials with ease. The authors Sanjana, Neville E., and Sawyer B.

Fuller demonstrate the first use of inkjet printing technique to influence neural cell behavior by printing improved island culture patterns.

Inkjet printing technique can also be useful in the field of tissue engineering due to its high throughput capability by automatic processes that create precise control and accuracy. Inkjet printing technique can be useful to create viable cellular patterns. Research shows that inkjet printing has potential to be adapted to tissue engineering and colony pattern applications [11].



**Figure 3.5** Schematic of inkjet printing.  
Source: [10]

## **CHAPTER 4**

### **COMSOL MULTIPHYSICS**

#### **4.1 Background**

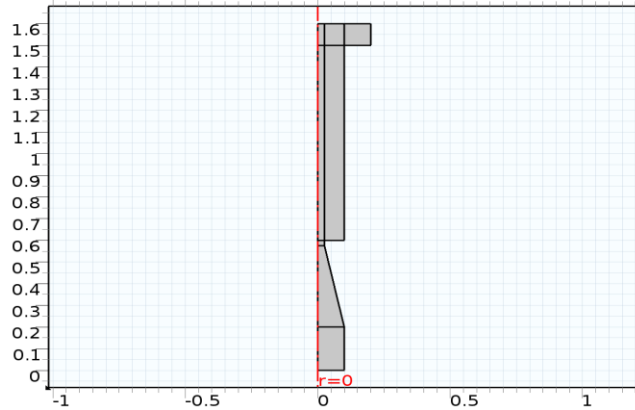
COMSOL Multiphysics is finite element analysis software based on advanced formulas and methods. This software helps model multi physical properties from the most basic to complex ones. This software offers 30 add-on products from electrical, mechanical, fluid flow, and chemical applications. Another feature this software provides is compatibility with other programs such CAD and Matlab to ease usability.

#### **4.2 Materials and Methods**

COMSOL Multiphysics will be used to model electrospinning based on a model of inkjet printing technique. Since the parameters of inkjet printing and electrospinning are similar, changing these parameters to resemble that of electrospinning will help model this process.

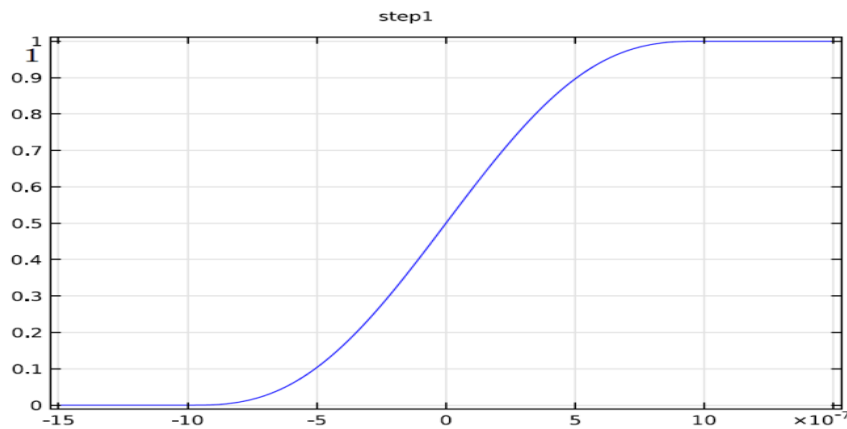
The first step is to obtain a working inkjet printing model. This has been accomplished with the aid of COMSOL Multiphysics guide. The first step is to define what physics to use. Laminar two-phase fluid flow is used because there are interacting flowing fluids, ink and air. Traditionally this is difficult to model because the regions that these two fluids interact create compressibility in an incompressible differential equation. COMSOL software solves this issue by giving the user the ability to customize the differential equation [9].

After choosing the physics that will be used, the geometry must be created. To create the geometry, four rectangles and one polygon are used (Figure 5.2).



**Figure 4.6** Geometry of inkjet printing in millimeters.

Once the geometry is created, materials must be assigned. In this study, air and ink are used. The physical properties of these materials are determined by the COMSOL program, but can be changed according to application. After materials are added, global definitions are created to restrict the inkjet simulation. A step function is used to eject the ink into droplets and an inlet velocity is chosen to be a parabolic function.



**Figure 4.7** Step function used to eject ink.

After these parameters are set, the next step is to assign boundary conditions which will define the inlet, outlet, and walls. The inlet is set as the velocity of the parabolic function where the nozzle ends. The outlet gives the simulation a place where the ink will be collected like a collector plate in electrospinning. Lastly, walls are added to the geometry to contain the ink and air.

Finally, after completing these steps, a fine mesh is created to begin analysis. To refine the study, certain settings must be applied such as time settings and the range of times to observe.

## CHAPTER 5

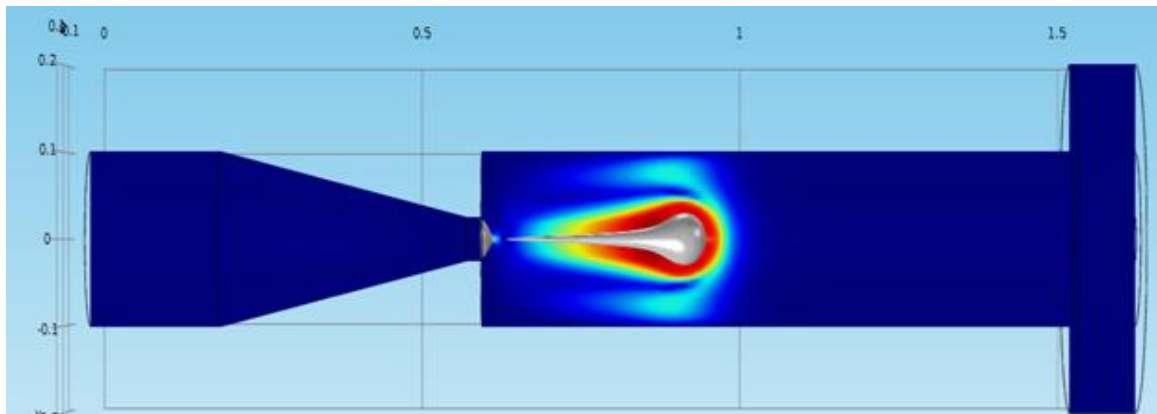
### RESULTS

#### 5.1 Results of Inkjet Model

After creating the geometry and inputting physical properties the results indicate that a functional inkjet model is created.

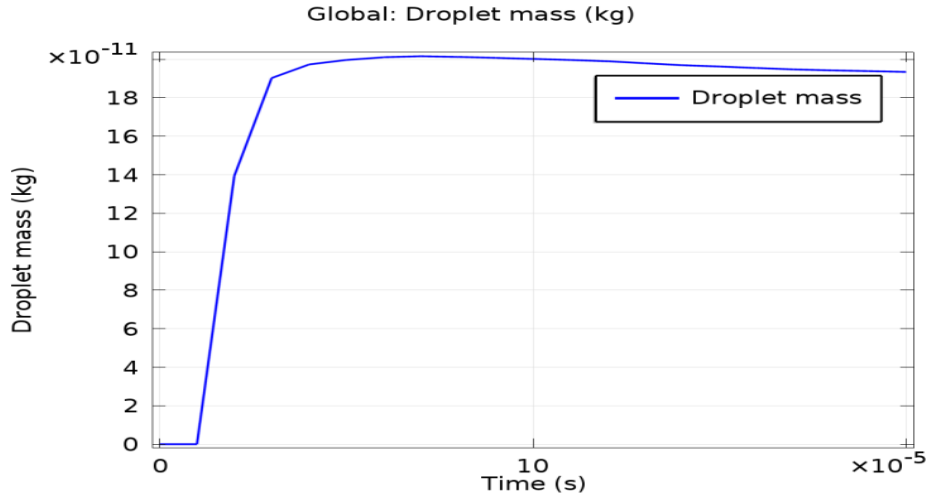
**Table 5.1** Given Expressions for Inkjet Model

Name	Expression	Description
v_inr	$4.5[\text{m/s}] * ((r + 0.1[\text{mm}]) / 0.2[\text{mm}]) * (1 - ((r + 0.1[\text{mm}]) / 0.2[\text{mm}]))$	r-dependent inlet velocity factor
inlett	$\text{step1}(t[1/\text{s}] - 1\text{e-}6) - \text{step1}(t[1/\text{s}] - 13\text{e-}6)$	t-dependent



**Figure 5.8** Droplet ejecting from nozzle approaching collector plate.

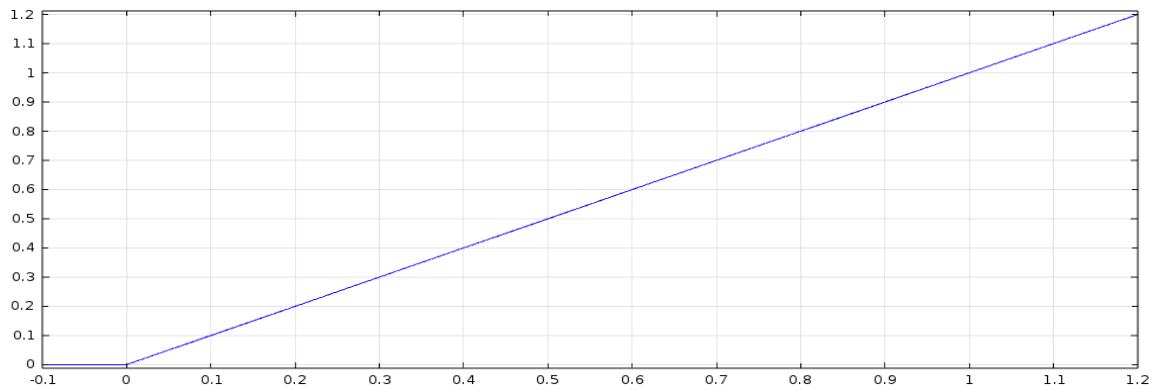




**Figure 5.9** Graph of droplet mass in kilograms.

### 5.2 Refined Methods of Inkjet Model

For the refined inkjet model, parameters are changed to try to accomplish a jet instead of a droplet ejection. The geometry and physics used are not altered and most of the global definitions remain the same. The step function is changed to a ramp function of slope 1 as shown below.

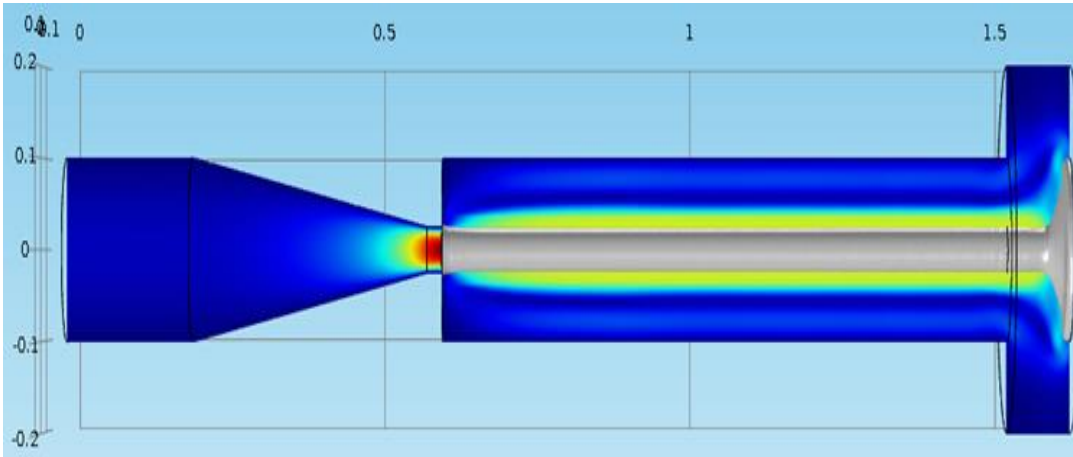


**Figure 5.10** Newramp function to eject ink.

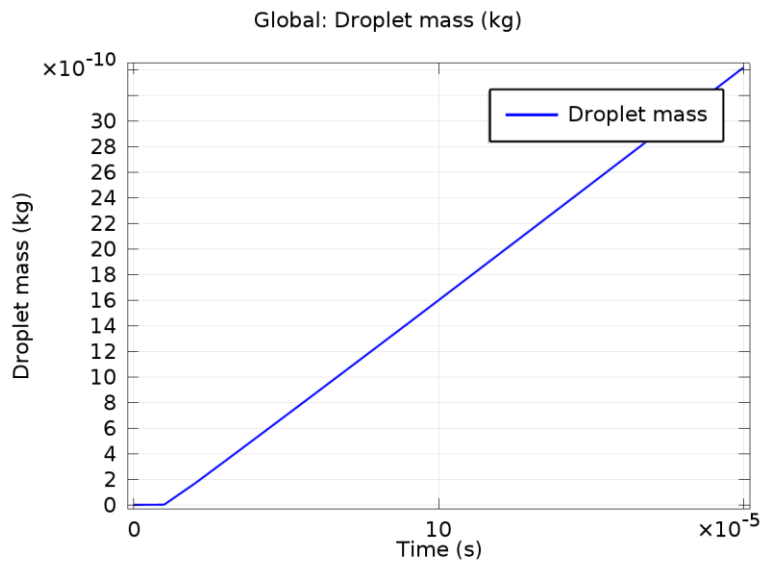
After defining the new step functions, the remainder of the simulation stays the same. The results show that there is a jet initiation phase but stays in the jet phase until reaching the target.

### 5.3 Refined Results of Inkjet Model

Once refining the input method to a ramp function the result shows a continuous jet from the nozzle to the target.

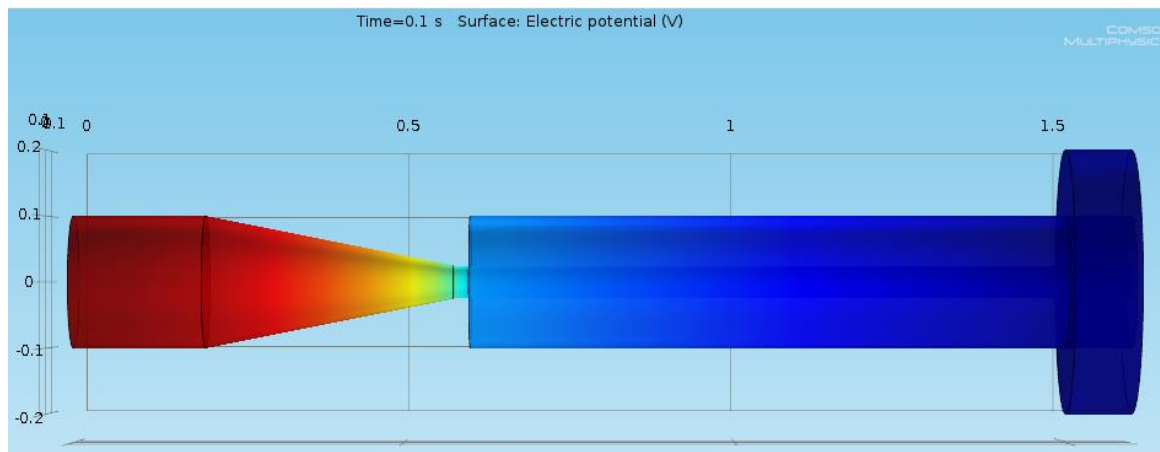


**Figure 5.11** Jet initiation phase continued until target is reached.

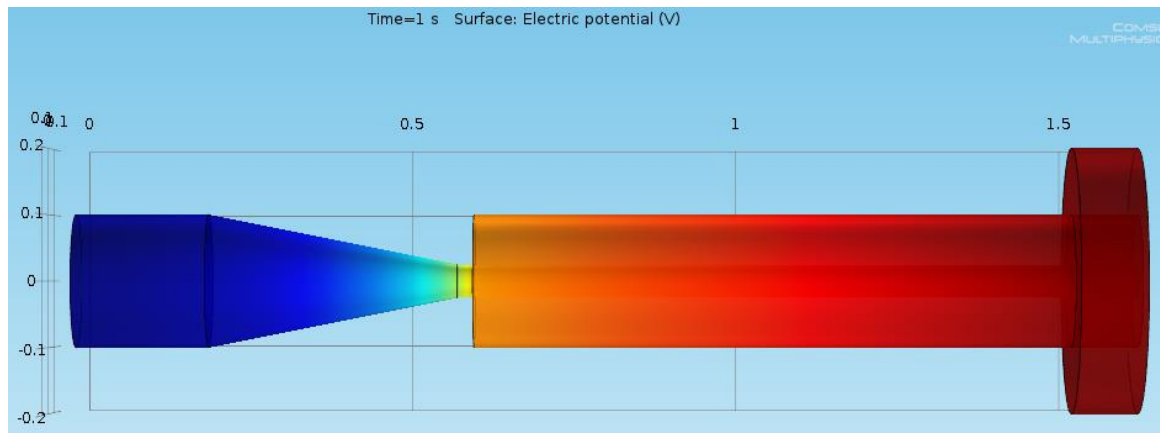


**Figure 5.13** Graph of droplet mass in kilograms.

The last phase of this model is to finally add another physics which is the basis of electrospinning and to replace ink with polyethylene. The physics that is added to this laminar two-phase flow is electrostatics. For electrostatic physics, there must be a positive charge at the tip of the nozzle which will be terminal 1 and a ground charge at the collector plate which will be terminal 2. After creating the electrostatic potential, there has to be zero charge in the tube where the polyethylene will flow; and this is done by defining domains that will enable zero charge to be inputted at certain locations.



**Figure 5.14** Electric potential at 0.1 seconds.

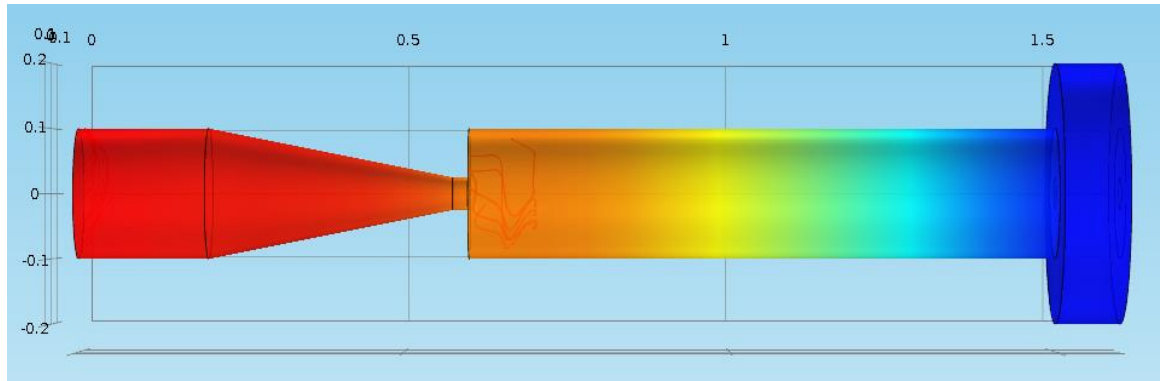


**Figure 5.15** Electric potential at 1 second.

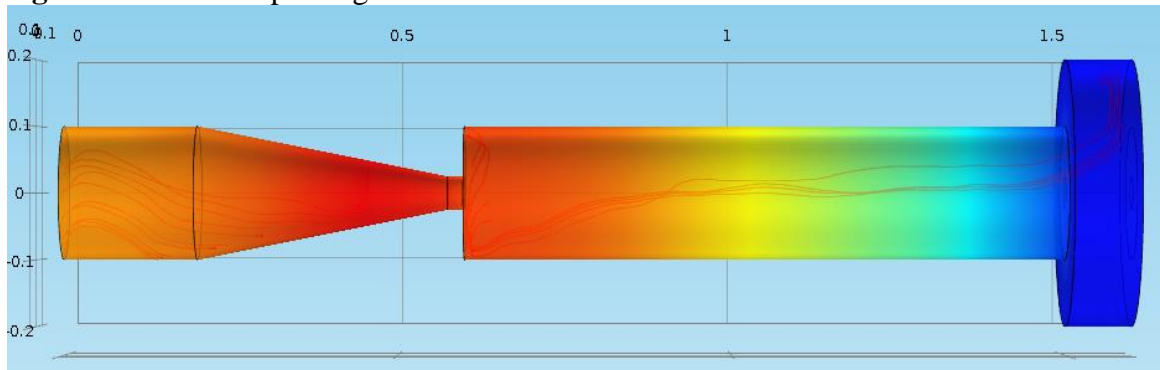
These two figures indicate that there is an electric potential propagation, which could mean that the charged ink reached the target. There is no definite proof of this since the polyethylene is not seen to travel.

To attempt to resolve this issue, a higher electric potential is added. Instead of 60 kilovolts, the input electrostatic physics is changed to 80 kilovolts. Also the grounded terminal 2 is given a negative charge. These changes show that strands are being ejected from the nozzle but in an unexpected way. This unexpected output could be due to several factors such as the viscosity of the fluid, the increased electrical charge, or the partial differential equation provided by COMSOL.

These parameters affect electrospinning and alter the model. This model is simplified, being simplified can cause problems when trying to input certain parameters. Increasing the voltage theoretically and experimentally is known to decrease fiber thickness. If voltage exceeds a critical amount the filaments scatter. Figure 5.16 shows multiple scattered fibers ejecting from the nozzle. After the simulation reaches one second it is seen that the fibers ultimately reaches the intended target, but there is no clear indication of whipping motion. This could be due to the properties of the fluid or the partial differential equation that is given by COMSOL.



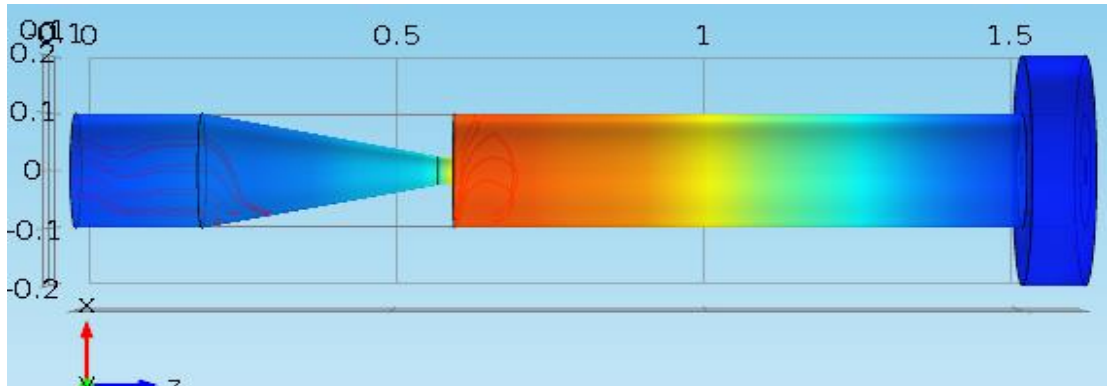
**Figure 5.16** Electrospinning model at .1 second.



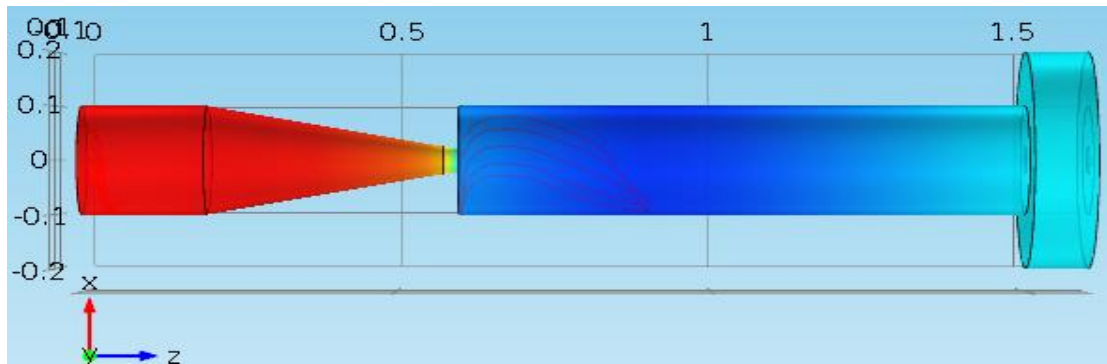
**Figure 5.17** Electrospinning model at 1 second.

Once the electrospinning model shows a streamline of fluid additional steps are taken to understand the parameters in detail. Focusing on the effect of voltage with respect to time will give a better and clear understanding of what is occurring as the voltage is manipulated.

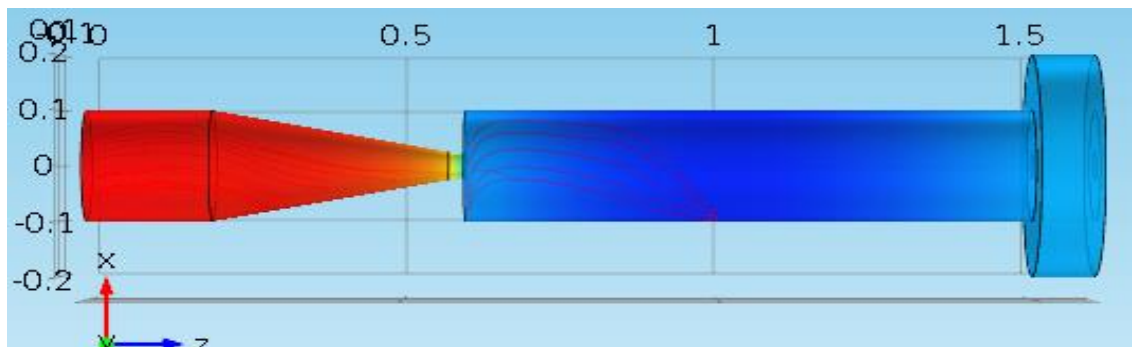
Other studies have shown as the voltage decreases the ejection of the nano-fiber may be hindered due to the voltage not being enough to overcome the surface tension. However, if voltage is high it can lead to scattering of fibers and variable fiber diameter. To determine at what voltage the fluid will reach the target a voltage dependent study is conducted. In this voltage dependent study the inlet voltage is started from 10 kilovolts with an increment of 10 kilovolts until 80 kilovolts.



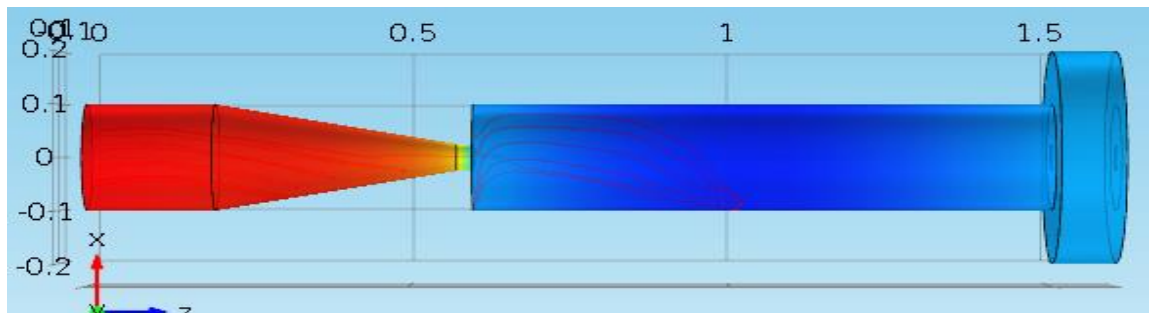
**Figure 5.18** Electrospinning model at 10 kilovolts at .1 second.



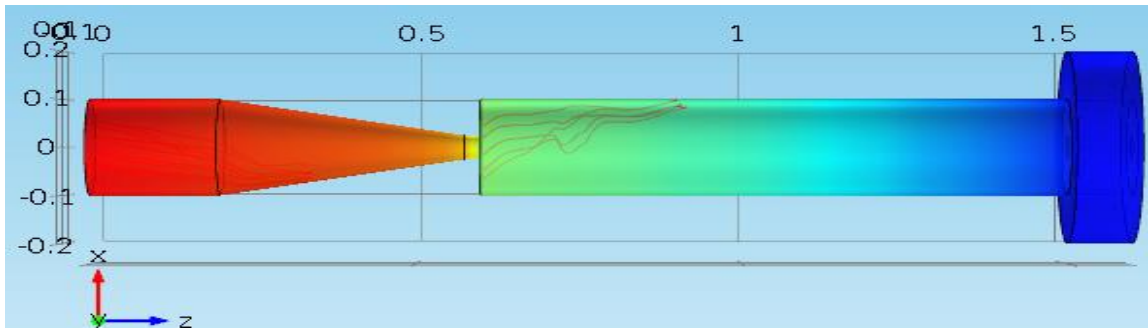
**Figure 5.19** Electrospinning model at 10 kilovolts at 1 second.



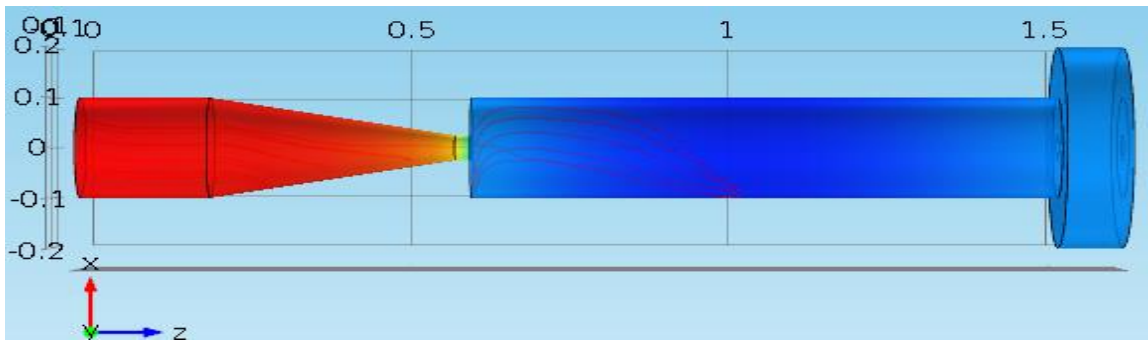
**Figure 5.20** Electrospinning model at 20 kilovolts at .1 second.



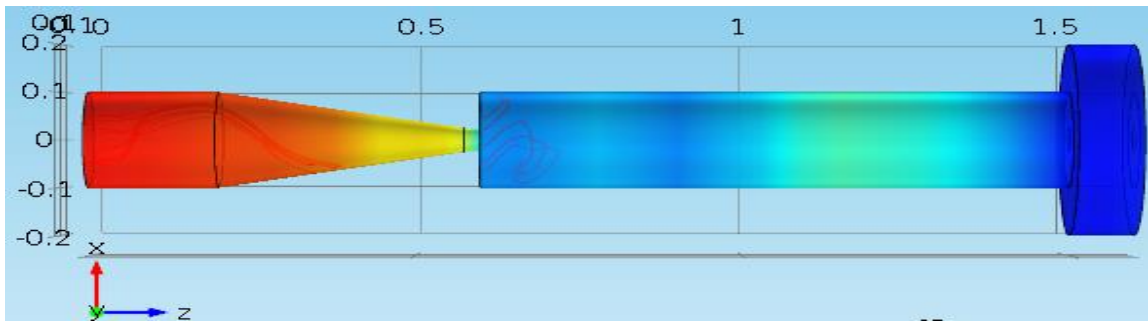
**Figure 5.21** Electrospinning model at 20 kilovolts at 1 second.



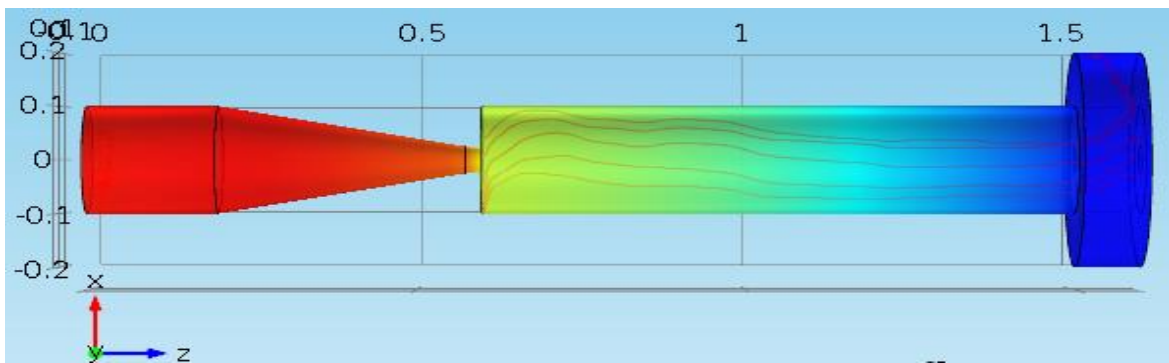
**Figure 5.22** Electrospinning model at 30 kilovolts at .1 second.



**Figure 5.23** Electrospinning model at 30 kilovolts at 1 second.



**Figure 5.24** Electrospinning model at 40 kilovolts at .1 second.



**Figure 5.25** Electrospinning model at 40 kilovolts at 1 second.

Changing the voltage to identify the effects of electrospinning provides a better understanding of the process of electrospinning. Once reaching 40 kilovolts and above the fluid reaches the collector plate at 1 second.



## CHAPTER 6

### DISCUSSION

#### 6.1 Discussion of Results

Electrospinning is an applied technique to generate nonwoven mats that are useful in many fields such as tissue engineering and filter applications. The simple technique contributes to the reason of its popularity and use to create submicron fibers. Even though the technique is simple there is little research of the uncertainty that causes non-reproducible results [12]. This research uses inkjet printing as a comparable technique with certain parameter changes to describe the mechanisms of producing reproducible results.

Using inkjet printing technique as a basis for electrospinning is possible because of similar parameters. After establishing a working inkjet printer, there must be several parameter changes to create an electrospinning process. The first parameter to be changed is the inlet wave form so as to be a ramp function instead of being a step function. Before changing the wave form, it is expected that there is a drop formation ejecting from the end of the nozzle. After changing the wave form, there is a jet initiation phase that is similar to the one happening in the process of electrospinning. However, it can be noticed that there is no Taylor cone from which the jet is ejected. The lack of the Taylor cone can be due to the lack of electrostatic forces.

The first trial to run the inkjet printer with a different wave form has shown success in obtaining expected results. The continuation of this process can be achieved by adding electrostatic physics to the model. The electrostatic physics include inlet

electric potential at the tip of the nozzle to be 60 kilovolts and a negatively charged collector plate. The charge conservation and electric field follow Gauss' law.

After inputting the initial conditions, the results have indicated that there is a propagation of the electric current from the nozzle to the collector plate. This could indicate that the charged ink is also propagating towards the intended target. However, the ink is not seen traveling throughout the model. The addition of the two models may not converge but the electrostatic forces are seen to propagate, which can be due to the charged ink or due to the electric dissipation.

To resolve this issue the ground collector plate is changed to have a negative charge. Also the position of the laminar flow physics is replaced with the electrostatic physics. After these changes the model shows a streamline of fluid from the nozzle to the intended target. The streamline does not replicate the expected motion of the electrospun fiber as in the literature suggests. This unexpected result can be caused by many factors such as the applied voltage, the viscosity of the fluid, or the generally given equations by COMSOL.

The voltage dependent study showed that there is no fluid reaching the collector plate at the range from 10-30 kilovolts. However, at 40 kilovolts and higher the fluid reaches the collector plate. This study shows that applying a different voltage will affect the electrospinning process.

The results indicate that there is a transformation of the droplet from the inkjet model to the jet phase and finally a streamline fluid to the collector plate. Research shows that there are nano-fibers created from as little as 10 kilovolts up to 60 kilovolts. The results of this thesis, however, show that there is fiber formation at 10 kilovolts but

did not reach the collector plate. The difference in results between other research and this thesis could be due to the lack of solution parameters such as molecular weight, concentration, and surface tension. The parameters that are chosen to define the material are given by COMSOL's material library and are limited.

The original objective for this thesis is to model electrospinning using inkjet printing as a basis. After refining the simulation of inkjet printing and analyzing the results, it has shown that starting from an inkjet model to electrospinning is possible due to the parameter similarity. This model is just a start since not all the parameters are included; however, refining the model further can create more accurate and expected results.

After inputting the electrostatic physics, there is an unexpected result regarding the electric dissipation. It can be seen that at 10 kilovolts and at .1 second the nozzle is not yet charged. This could be due to the ramp function with the lower voltage not propagating as quickly as required. The higher electric potential above 10 kilovolts shows that the nozzle is always charged. To further understand what is occurring, there could be a study that reduces the increments of voltage and analyze the results to see if this unexpected phenomenon only occurs at lower voltage.

There are still future studies that can be done to achieve a more realistic model. One step that can be taken toward the right direction would be to use a material that reflects all the solution parameters that affect electrospinning in the model. The solution would give a more defined and realistic model. Also, a processing parameter that can be changed to mimic realistic electrospinning would be the collector plate distance from the nozzle. In this model the distance is 1 cm, however, in literature

electrospinning collector distance from nozzle can range from 10 to 15 cm. These two parameters would greatly affect the model and produce realistic solutions.

## **6.2 Future Studies**

This simulation shows intriguing results but not conclusive. Future studies are needed to confirm the formation of the Taylor cone and whipping motion when electrostatic forces are applied with laminar fluid flow physics. Finite element analysis helps understand the possible outcomes of physical properties. Since inkjet printing method is more understood and modeled, changing the parameters of this to simulate electrospinning is possible.

The need to fabricate reproducible results by this simple method is crucial to be able to produce nanofibers in large scale. Possible future studies can include the usage of different user inputted equations. Using COMSOL's built in is acceptable in the case for inkjet printing, but using different partial differential equations can improve results.

## **6.3 Conclusion**

Tissue engineering, drug delivery, biomaterials, and electronics are fields that can be aided by electrospinning. The fabrications of nano-scale properties cause major scientific improvements. To be able to fabricate reproducible results is the key to this simplistic method.

Modeling electrospinning is beneficial to understand how the parameters affect the physical properties to make it possible to create reproducible results. To model electrospinning, inkjet printing is used as a basis since it is understood. Inkjet printing

has similar parameters as electrospinning such as velocity, electrostatic forces, and fluid viscosity. After creating a working inkjet model, an electrospinning model can be created by changing these parameters. There is still further research that can be done to improve this analysis, however, there is evidence to show this is a possible method to model electrospinning.

## REFERENECS

- [1] S.Thandavamoorthy, G. Bhat, R.Tock, S. Parameswaran, and S.Ramkumar. "Electrospinning of nanofibers." *Journal of Applied Polymer Science* 96.2 (2005):557-69.
- [2] R. Anamarija. "Electrospinning process: Versatile preparation method for biodegradable and natural polymers and biocomposite systems applied in tissue engineering and drug delivery." *Applied Surface Science* (2014)
- [3] S.Travis, and H. Recum. "Electrospinning: Applications in drug delivery and tissue engineering." *Biomaterials* 29.13 (2008): 1989-2006.
- [4]B. Nandana, and S. Kundu. "Electrospinning: A fascinating fiber fabrication technique." *Biotechnology Advances*, Volume 28, Issue 3, May–June 2010, Pages 325-347, ISSN 0734-9750
- [5] M. Šimko, J. Erhart, and D. Lukáš. "A mathematical model of external electrostatic field of a special collector for electrospinning of nanofibers." *Journal of Electrostatics*, Volume 72, Issue 2, April 2014, Pages 161-165, ISSN 0304-3886
- [6] X. Hu, S. Liu, G. Zhou, Y. Huang, Z.Xie, and X.Jing. "Electrospinning of polymeric nanofibers for drug delivery applications." *Journal of Controlled Release*, Volume 185, 10 July 2014, Pages 12-21, ISSN 0168-3659
- [7] H. Wijshoff. "The dynamics of the piezo inkjet printhead operation." *Physics Reports*, Volume 491, Issues 4–5, June 2010, Pages 77-177, ISSN 0370-1573
- [8]G. Cummins, R. Kay, J. Terry, M. Desmulliez, and A. Walton. "Optimization and characterization of drop-on-demand inkjet printing process for platinum organometallic inks." *Electronics Packaging Technology Conference (EPTC), 2011 IEEE 13th* , Volume., no., pp.256,261, 7-9 Dec. 2011
- [9] K. Lund. "Modeling of two-phase flows." *Modeling of Two-Phase Flows COMSOL*, 2007. Web. Retrieved on Nov 12, 2014, from <http://www.comsol.com/paper/download/14823/Lund.pdf>
- [10]N. Sanjana, and S. Fuller. "A Fast flexible ink-jet printing method for patterning dissociated neurons in culture." *Journal of Neuroscience Methods* 136.2 (2004): 151-63.
- [11] E. Roth, T. Xu, M. Das, C. Gregory, J. Hickman, and T. Boland. "Inkjet printing for high-throughput cell patterning." *Biomaterials* 25.17 (2004): 3707-715.

- [12] G. Collins, J. Federici, Y. Imura, and L. Catalani. "Charge generation, charge transport, and residual charge in the electrospinning of polymers: A review of issues and complications." *Journal of Applied Physics* 111.4 (2012): 044701
- [13] M. Lee, N. Kim, and S. Yoon. "On pinchoff behavior of electrified droplets." *Journal of Aerosol Science*, Volume 57, March 2013, Pages 114-124, ISSN 0021-8502
- [14] N. Okutan, P. Terzi, and F. Altay. "Affecting parameters on electrospinning process and characterization of electrospun gelatin nanofibers." *Food Hydrocolloids*, Volume 39, August 2014, Pages 19-26, ISSN 0268-005X
- [15] F. Ahmed, B. Lalia, and R. Hashaikeh. "A review on electrospinning for membrane fabrication: challenges and applications." *Desalination*, 30 October 2014, ISSN 0011-9164
- [16] N. Zhu, and X. Chen. "Biofabrication of tissue scaffolds." *Advances in Biomaterials Science and Biomedical Applications*, ISBN: 978-953-51-1051-4, InTech, DOI: 10.5772/54125.
- [17] N. Thoppey, J. Bochinski, L. Clarke, and R. Gorga. "Unconfined fluid electrospun into high quality nanofibers from a plate edge." *Polymer* 51.21 (2010): 4928-936.