

Fall 1-31-2013

## Quantification of human motion on roller coaster rides

Chirag Burman  
*New Jersey Institute of Technology*

Follow this and additional works at: <https://digitalcommons.njit.edu/theses>



Part of the [Biomedical Engineering and Bioengineering Commons](#)

---

### Recommended Citation

Burman, Chirag, "Quantification of human motion on roller coaster rides" (2013). *Theses*. 140.  
<https://digitalcommons.njit.edu/theses/140>

This Thesis is brought to you for free and open access by the Electronic Theses and Dissertations at Digital Commons @ NJIT. It has been accepted for inclusion in Theses by an authorized administrator of Digital Commons @ NJIT. For more information, please contact [digitalcommons@njit.edu](mailto:digitalcommons@njit.edu).

## **Copyright Warning & Restrictions**

The copyright law of the United States (Title 17, United States Code) governs the making of photocopies or other reproductions of copyrighted material.

Under certain conditions specified in the law, libraries and archives are authorized to furnish a photocopy or other reproduction. One of these specified conditions is that the photocopy or reproduction is not to be “used for any purpose other than private study, scholarship, or research.” If a user makes a request for, or later uses, a photocopy or reproduction for purposes in excess of “fair use” that user may be liable for copyright infringement,

This institution reserves the right to refuse to accept a copying order if, in its judgment, fulfillment of the order would involve violation of copyright law.

**Please Note: The author retains the copyright while the New Jersey Institute of Technology reserves the right to distribute this thesis or dissertation**

Printing note: If you do not wish to print this page, then select “Pages from: first page # to: last page #” on the print dialog screen

The Van Houten library has removed some of the personal information and all signatures from the approval page and biographical sketches of theses and dissertations in order to protect the identity of NJIT graduates and faculty.

## **ABSTRACT**

### **QUANTIFICATION OF HUMAN MOTION ON ROLLER COASTER RIDES**

**by  
Chirag Burman**

Case reports have been published of people experiencing symptoms of traumatic brain injury (TBI) and/or ailments of the vascular tissue around the head. These reports pointed towards G-forces, a scalar measure without a specified direction, which represent the measure of the acceleration of an object divided by acceleration caused by gravity ( $9.81 \text{ m/s}^2$ ), as a cause of said injuries. Research has been conducted on quantifying the G-forces experienced while on roller coasters, as well as the change in heart rate. However these studies have not been able to show a link between roller-coasters and symptoms.

This thesis aims to conceive of a system to capture total body motions and physiological properties, and to prove that the data can be successfully recorded. A system is built which would contain a series of sensor systems to sense and record various biomechanical and physiological parameters; with these data one can assess effects on the body. Along with this system, a BioHarness device is used on participants, which would record a number of physiological parameters. Testing is conducted on fourteen subjects on three rides, and the data are evaluated to see whether total body motions are successfully captured.

# **QUANTIFICATION OF HUMAN MOTION ON ROLLER COASTER RIDES**

**by**

**Chirag Burman**

**Advisors: Dr. Bryan Pfister and Mr. Michael Bergen**

**A Thesis**

**Submitted to the Faculty of**

**New Jersey Institute of Technology**

**in Partial Fulfillment of the Requirements for the Degree of  
Master of Science in Biomedical Engineering**

**Department of Biomedical Engineering**

**January 2013**

Blank Page

**APPROVAL PAGE**

**QUANTIFICATION OF HUMAN MOTION ON ROLLER COASTER RIDES**

**Chirag Burman**

---

Dr. Bryan Pfister, Thesis Advisor  
Associate Professor of Biomedical Engineering, NJIT

Date

---

Mr. Michael Bergen, Committee Member  
Adjunct Professor, NJIT

Date

---

Dr. William Hunter, Committee Member  
Professor of Biomedical Engineering, NJIT

Date

## **BIOGRAPHICAL SKETCH**

**Author:** Chirag Burman  
**Degree:** Master of Science  
**Date:** December 2012

### **Undergraduate and Graduate Education:**

- Master of Science in Biomedical Engineering,  
New Jersey Institute of Technology, Newark, NJ, 2012
- Bachelor of Science in Biomedical Engineering,  
Rensselaer Polytechnic Institute, Troy, NY, 2009

**Major:** Biomedical Engineering



This thesis is dedicated to my family, Chandra, Rupa, and Rachna,  
and my friends who supported me through this process keeping  
me level headed and motivated.

## ACKNOWLEDGMENT

I would like to thank Dr. Bryan Pfister for being my advisor and providing me the opportunity to participate in this research project. I'd like to thank Michael Bergen for providing invaluable assistance as well as co-chairing my thesis committee. I'd like to thank Dr. Richard Foulds for being a member of my committee as well as teaching me about the trakSTAR™ system and providing me one to use for my research project. I'd like to thank Mr. Larry Chickola of Six Flags for making this all possible, by providing the roller coasters, the mouthpiece, his time, and assistance on the project. I'd like to thank Dr. Maxine Kwan for helping me with Matlab. I'd like to thank Negar, Jonathan, Anjali, Joe, and Millie for all of your assistance in data collection and logistics. I'd like to thank Ghaith and John Hoinowski for all of their help, building the HAMPRE and fabricating fasteners for the sensors would not have been possible without them.

I'd like to thank my family and friends for keeping me going through the ups and downs of this project and for keeping me level headed.

## TABLE OF CONTENTS

<b>Chapter</b>	<b>Page</b>
1 INTRODUCTION.....	1
1.1 Objective.....	1
1.2 Roller Coasters and Injuries.....	1
1.3 Previous Study.....	4
1.4 Further Exploration.....	5
2 COLLECTION APPARATUS.....	6
2.1 HAMPRE (Human Amusement Motion and Physiology Recording Equipment).....	6
2.2 trakSTAR™.....	11
2.3 Mouthpiece.....	14
2.4 Software.....	16
3 DATA COLLECTION.....	18
3.1 Verification and Validation.....	18
3.2 Subject Selection.....	20
3.3 Data Collection.....	20
3.4 Collection Failures.....	22
4 RESULTS.....	24
4.1 Cropping of Raw Data.....	24

**TABLE OF CONTENTS**  
**(Continued)**

<b>Chapter</b>	<b>Page</b>
4.2 Batman Data.....	28
4.3 Nitro Data.....	33
4.4 Superman Data.....	37
5 CONCLUSIONS AND FUTURE WORK.....	39
5.1 Conclusions.....	39
5.2 Future Work.....	41
5.3 Improvements.....	41
APPENDIX A: BATMAN DATA LOADING SCRIPT.....	43
APPENDIX B: NITRO DATA LOADING SCRIPT.....	44
REFERENCES.....	45

## LIST OF TABLES

<b>Table</b>		<b>Page</b>
4.1	Batman data: sensor displacement relative to transmitter along the X axis.....	30
4.2	Batman data: sensor displacement relative to transmitter along the Y axis.....	32
4.3	Nitro Data: Hip Sensor movement along the z-axis.....	35

## LIST OF FIGURES

<b>Figure</b>	<b>Page</b>
1.1 Head Injury Criterion (HIC) Equation.....	4
1.2 Head Injury Power (HIP) Equation.....	4
2.1 Unassembled HAMPRE (trakSTAR™, DATAQ, battery, and inverter).....	9
2.2 HAMPRE with all interior components connected.....	10
2.3 HAMPRE exterior and test.....	10
2.4 HAMPRE on a roller coaster.....	11
2.5 trakSTAR™ transmitter orientation.....	12
2.6 trakSTAR™ sensor orientation.....	12
2.7 Orthogonal directions of trakSTAR™ sensors relative to ride subjects.....	13
2.8 trakSTAR™ unit.....	13
2.9 trakSTAR™ transmitter (left) and sensor (right).....	14
2.10 Biteplate mouthpiece and sensor orientations.....	15
2.11 Sportsguard mouthpiece.....	16
3.1 Verification of data collection from a trakSTAR™ sensor on Batman .....	19
3.2 trakSTAR™ sensor placement .....	21
4.1 Identification of head shaking physical marker .....	25
4.2 Ride data trial before trimming .....	26
4.3 Ride data trial after trimming .....	27

**LIST OF FIGURES**  
**(Continued)**

<b>Figure</b>	<b>Page</b>
4.4 trakSTAR™ transmitter orientation .....	29
4.5 trakSTAR™ sensor orientation .....	29
4.6 Pattern of oscillations along the x axis .....	31
4.7 Movement in the Z direction.....	33
4.8 Example of Nitro subject data demonstrating lift from seat .....	36
4.9 Pattern of lift out of seat on Nitro.....	37
4.10 Example of Superman ride data.....	38
5.1 Height vs. Motion on Batman.....	40
5.2 Weight vs. Motion on Batman.....	40

# CHAPTER 1

## INTRODUCTION

### 1.1 Objective

When going to an amusement park, patrons are drawn in by the most popular attractions, the roller coaster rides. These thrill-rides put patrons in faux danger, hurtling them at high speeds, drops, and inversions to create a sense of thrill. A sense of fear is added to these attractions by the ominous signs that are present at the entrance, an umbrella warning people not to ride if they have various medical conditions.

Advertisements for these rides use terms such as G-forces, and use the acceleration of the rides to attract people. However there is no disclaimer or advertisement telling patrons the extent of the movement their body will physically go through on these rides and there have only been a few studies giving threshold numbers for actual motions caused by these roller coaster rides. It was the aim of this study to create a system to capture total body motions, as well as physiological data from roller coaster rides.

### 1.2 Roller Coasters and Injuries

According to a case study by Rutsch et al., the most common neurological injuries associated with roller coaster rides are subdural hematoma and cervical artery dissection. [1] When riding roller coasters riders will experience higher adrenalin levels, leading to an increase in both heart rate and blood pressure. The case study presented two instances of roller coaster-associated subarachnoid hemorrhage (SAH), an injury characterized by



bleeding in the area between the brain and the thin tissues that cover the brain. SAH can be caused by a number of factors including bleeding from an aneurysm, an arteriovenous malformation (AVM), and head injury. [8]

Case 1 was that of a 40- year-old male who developed a strong headache during a roller coaster ride of approximately 3 minutes; this was followed by an asymptomatic interval of several minutes, followed by the rider experiencing two grand mal seizures. [1] The seizures were revealed to be caused by the rupture of an aneurysm on the anterior communicating artery.

Case 2 was that of a 41-year-old female, who was a smoker, but otherwise healthy. [1] She experienced a sudden strong headache during a roller coaster ride as well as double vision. SAH was discovered in a CT scan, which could not be explained by biological factors rheumatic or mycotic. [1] The case study hypothesized that the combination of stress-induced increases in systemic blood pressure and transient increases in foot to head g forces may lead to transient shifting of blood to the brain and hence may be a possible cause of SAH. Rutsch was only able to find two other case reports of roller coaster associated SAH in medical literature, a 32-year-old woman and a 28-year-old woman who died from SAH due to an aneurysm. Though these cases might have indicated a causal relationship, Rutsch pointed out that these were anecdotal reports, and do not prove a causal relationship between roller coasters and the occurrence of SAH. [1]

In a review of amusement park injuries and deaths, Braksick et al. reported on the case of a Japanese woman who developed a headache which lasted four days after riding three different roller coasters, which included a 229-foot drop and topping speeds in excess

of 81 mph, an MRI revealed bilateral chronic subdural hematomas. [2] The report on this woman referred to three previously published cases of subdural hematomas relating to roller coaster rides, and suggested an association. The author quotes “up-and-down, to-and fro, and rotary acceleration, which produce tensile and shearing stresses” when referring to the cause of subdural hematoma.[2] Braksick et al, found a total of sixteen case reports of neurological injury after amusement park rides from 1979 to 2000. [2]

Braksick et al. reviewed a study which looked at the cardiac response to roller coaster rides, where participants with portable cardiac monitors were subjected to a “double-loop corkscrew roller coaster with 3Gs of acceleration and speeds greater than 40mph for 94 seconds.”[2] The study found that all participants reached their maximum heart rate within 8 seconds, with a mean heart rate increasing from 70 beats/min up to a rate of 154 beats/min.[3] The study concluded that a rapid increase in heart rate could place individuals with underlying ischemic heart disease at risk for a cardiac event. [3]

This review published in 2002, indicated that calculation of G-forces on roller coasters had not been done. The unit “G” is unitless, as it is the measure of the acceleration of an object divided by acceleration caused by gravity ( $9.81 \text{ m/s}^2$ ). U.S. Navy centrifuge test data showed that a loss of consciousness at high Gs was 4.2 seconds, independent of the G level ( $>3\text{Gs}$ ). US Air Force research expanded on that in terms of rate of acceleration, gradual (0.1 G/s), rapid (1 G/s), or very high (6 G/s). They concluded that a rate of 1G/s caused loss of consciousness at an average of 5.4Gs (range of 3 to 8.4Gs). Braksick made the point that roller coasters may not cause these G forces at long enough duration to induce loss of consciousness. [2]

### 1.3 Previous Study

In a study by Pfister et al the G-forces exhibited by rides were collected and compared to those from a pillow fight and a 5mph bumper car collision. [4] The purpose of this was to compare these forces to those which cause traumatic brain injury (TBI). Studies have characterized head motion biomechanics, with the purpose of determining the effectiveness of head protection measures. [4] To assess injury, a federally mandated motor vehicle safety standard, the head injury criterion (HIC) is used. [4]

$$HIC = \left[ \frac{1}{(t_2 - t_1)} \int_{t_1}^{t_2} a(t) dt \right]^{2.5} (t_2 - t_1)$$

**Figure 1.1** Head Injury Criterion (HIC) Equation

The HIC evaluates linear accelerations of the head. Another criterion the head impact power (HIP) is a function of both linear and rotational accelerations and velocities in 3 dimensions. [4]

$$HIP = 4.5a_x \int a_x dt + 4.5a_y \int a_y dt + 4.5a_z \int a_z dt + 0.016\alpha_x \int \alpha_x dt \\ + 0.024\alpha_y \int \alpha_y dt + 0.022\alpha_z \int \alpha_z dt$$

**Figure 1.2** Head Injury Power (HIP) Equation

Accelerations in this study were gathered using a custom made biteplate with 3 linear accelerometers and 3 angular rate sensors. The accelerometers and sensors were mounted in

an orthogonal fashion; data was collected at a 10000 Hz sampling rate, with a 3000 Hz antialiasing filter over a total of 6 channels. [4]

Results of the study were compared to head kinematics data of an 18mph car crash test dummy simulation from Johns Hopkins University. The values from the car crash simulation far exceeded the velocities, accelerations, HIC, and HIP received from data collection. The maximum HIC value received from a roller coaster was 4.1, while an 18mph car crash produced a value of 28.1. The values of HIC were 2 to 3 orders of magnitude below the minimally accepted values of 390 for infants and 700 for adults. [4] The study found that the linear and rotational head accelerations produced by riding a roller coaster are similar to the well tolerated head motions experienced during a pillow fight or heading a soccer ball. [4] The study highlighted the misperception that roller coasters present a risk of TBI, due to a misunderstanding in the role of G-forces in TBI.

#### **1.4 Further Exploration**

The study conducted by Pfister put the G forces that are experienced on roller coaster rides into perspective. However, further exploration could be done into the motions that the human body experiences while riding roller coasters. The degree of movement between the head and the neck in particular is an area of interest, as it is a sensitive area of the body. To capture these motions a system would need to be developed to view relative motions that the human body experiences while riding roller coasters.

## CHAPTER 2

### COLLECTION APPARATUS

#### **2.1 HAMPRE (Human Amusement Motion and Physiology Recording Equipment)**

To capture the real time motions of riders while on the roller coasters, an apparatus which could ride along with the subjects was built. The apparatus needed to contain a trakSTAR™ system, a Windaq data recorder, a laptop computer, and a battery large enough to power all of these devices. It also needed to handle the stresses and forces that could be experienced on a ride, for example going upside down.

To fit all these devices next to a rider, a box was created to hold all of the devices in the adjacent seat. The design constraints were to create a box which would mimic the torso of a human in dimensions, have the equipment readily accessible in between trials, and would not create interference with electromagnetic field generated by the trakSTAR™. The box would also have to be held securely, and be determined safe to ride with by the Six Flags Great Adventure personnel.

To determine the size that would be required for the apparatus, considerations had to be made for the total size of the chassis, as well as the interior space. The laptop computer would have to be accessible, as well as removable. Space would be needed on the left side of the computer for access to USB ports, and space would be needed on the right side of the laptop for access to the power cord. The laptop would have to be fastened as to remain open, and held down to prevent movement independent of the box while on a ride. The trakSTAR™ and Windaq unit would have to be placed as to be accessible to USB and power. The outputs from both units, the mouthpiece from the Windaq unit and the sensor

and transmitter from the trakSTAR™ would have to be oriented to allow for them to be accessible to the subjects on the ride. Space considerations would also have to be made for the dry cell battery, as well as the power inverter. The power inverter would also need space on both ends to allow for ventilation to its built in fan, and accessibility to the power outlets built into it.

The chassis was made from plywood, with fasteners made from ABS plastic, as to not interfere with the electromagnetic field that would be generated by the trakSTAR™ system. The dimensions of the chassis were 24"x16"x10" (height, width, length). A 2" hole was drilled in the right side for the trakSTAR™ sensors as well as the Windaq mouthpiece. The transmitter was mounted to the exterior of the box, using a clamp made from ABS plastic, held in place by screws which did not create interference in the electromagnetic field. The transmitter was oriented with the +X orthogonal direction facing the subject and the -Y direction projecting outwards from the box.

To secure the devices on the interior of the apparatus, fasteners were made from ABS plastic, which were form fitted to the laptop, as well as the battery. These fasteners were screwed in, and were held in place by wing nuts, to allow for their removal.

To power the devices, a 12 Volt 35 AH dry cell battery was used, this battery was chosen as it would be adequate to provide power for both the trakSTAR™, as well as the battery charger for the laptop computer. It provided 5 hours of power to the HAMPRE, before it was swapped out. An automobile power inverter was converted to take power directly from the battery, turning DC to AC current, and was fastened to a shelf in the HAMPRE chassis.

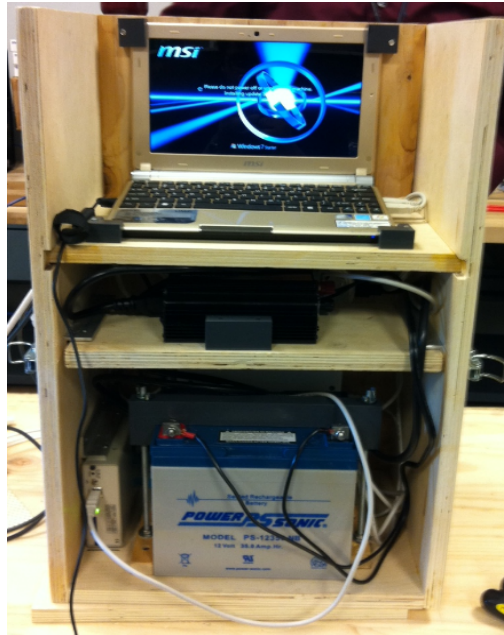
Because the seats in the roller coaster were not flat as to create a comfortable seat for the rider, a surface to place the HAMPRE box on was created. To create a rounded bottom, a broken water test dummy was provided by Six Flags. The back and the seat of the dummy were cut out to create a surface to place the HAMPRE in the seat.

To secure the apparatus on the three rides, different approaches had to be taken for each one due to differences in the safety harnesses. For Batman, the safety harness was an over the shoulder safety harness which clamped down and buckled into the seat. Compensation for the larger depth of the box was managed by using ratchet straps which wrapped around the harness and through the seat, compensating for the lack of ability to fully buckle the shoulder restraint using the standard buckle provided. The safety harness on Nitro consisted of a lap bar, because the apparatus was a box shape, it could not be fastened by a lap bar alone. To secure the box ratchet straps were used to hold the box down into the seat, the straps were fed through the seat and back over to hold it from the top down. The safety harness on superman, proved to be the easiest to use with the box, as it had both an over the shoulder and lap component, and being that it was a newer roller coaster the harness had space for a larger girth to fit. The box fit into the superman safety harness by itself and required no extra straps.

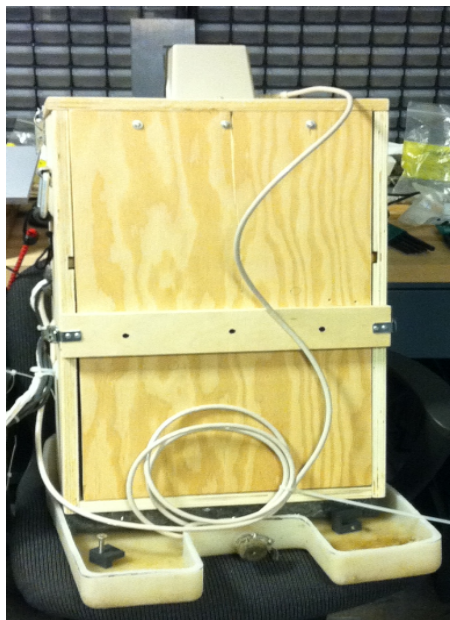


**Figure 2.1** Unassembled HAMPRE (trakSTART™, DATAQ, battery, and inverter)





**Figure 2.2** HAMPRE with all interior components connected



**Figure 2.3** HAMPRE exterior and test seat

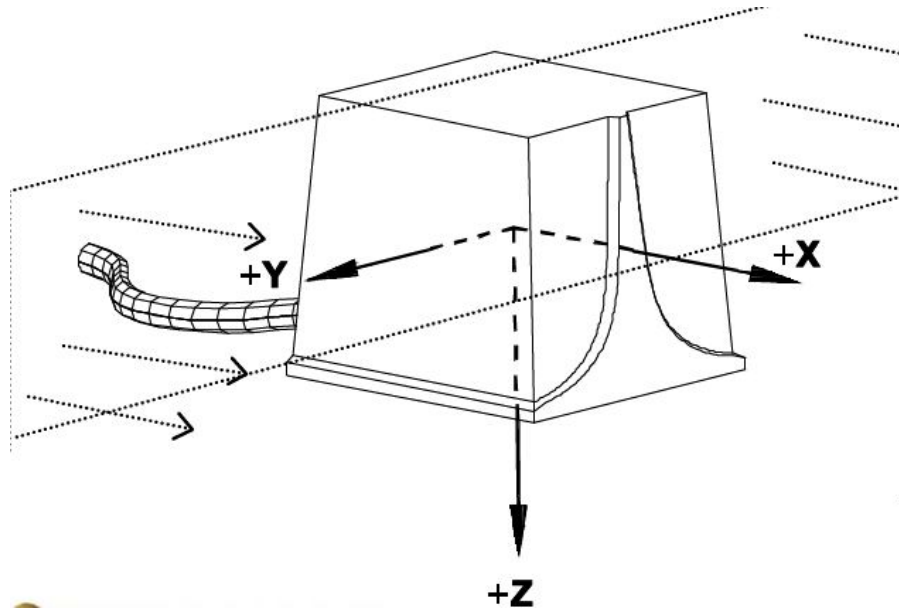


**Figure 2.4** HAMPRE on a roller coaster

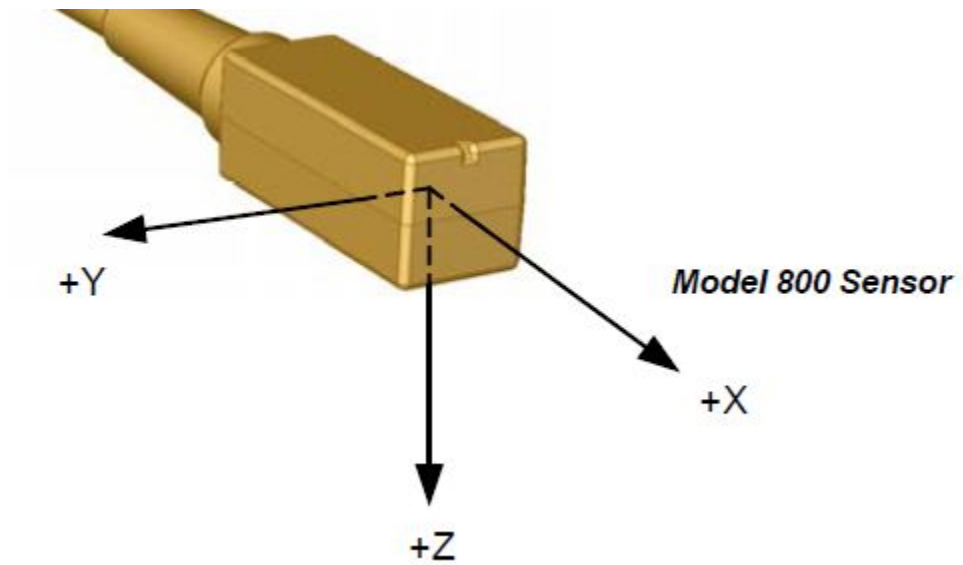
## **2.2 trakSTAR™**

The trakSTAR™ is a 3D spatial tracking system, which uses an electromagnetic field to track up to 4 sensors each with 6 degrees of motion (X, Y, Z, azimuth, elevation, and roll). An electromagnetic field is produced by a transmitter, while the relative positions and orientations of the 4 sensors are tracked in real time. While the trakSTAR™ system is distorted by the presence of magnetic metals, distortion on the roller coasters was tested before being used in the study.

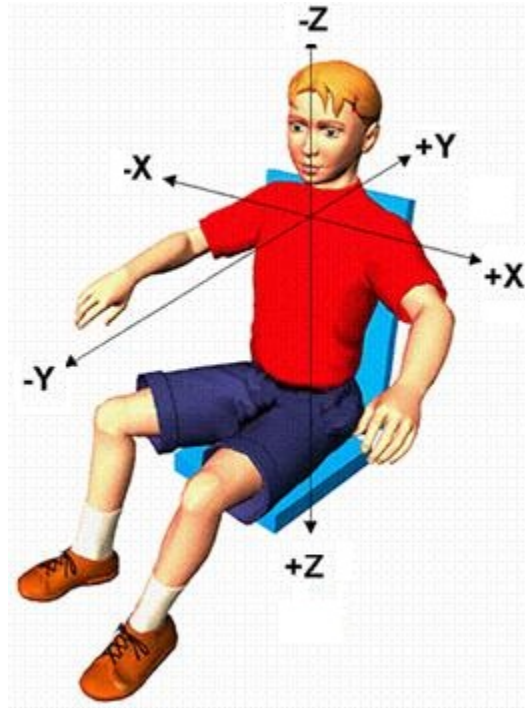
The transmitter was oriented with the +X orthogonal direction facing the subject and the -Y direction projecting outwards from the box.



**Figure 2.5** trakSTAR™ transmitter orientation [5]



**Figure 2.6** trakSTAR™ sensor orientation [5]

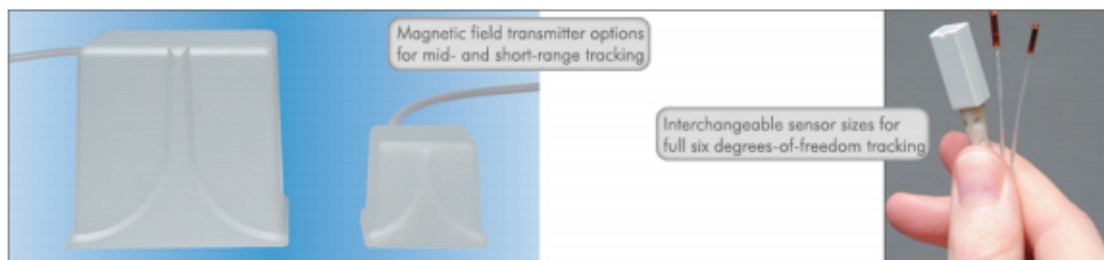


**Figure 2.7** Orthogonal directions of trakSTAR™ sensors relative to ride subjects

The trakSTAR™ has the potential to collect at up to 600 samples per second and has a sensor range of up to 30 inches away from the transmitter. In a seated position, sensor data from the head, shoulder, and waist were within range on all rides. [5]



**Figure 2.8** trakSTAR™ unit [5]



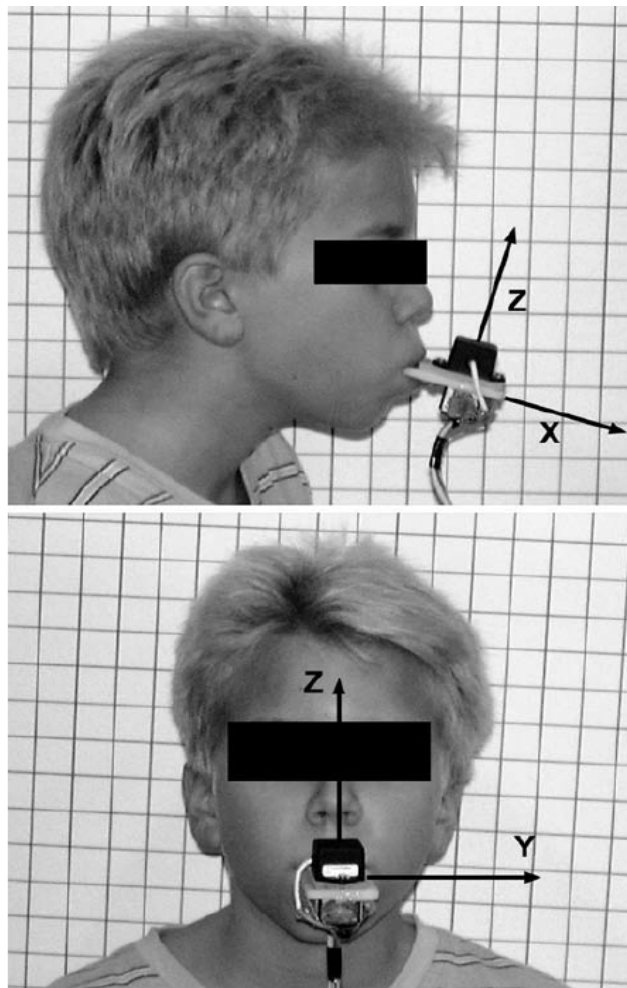
**Figure 2.9** trakSTAR™ transmitter (left) and sensor (right) [5]

### 2.3 Mouthpiece

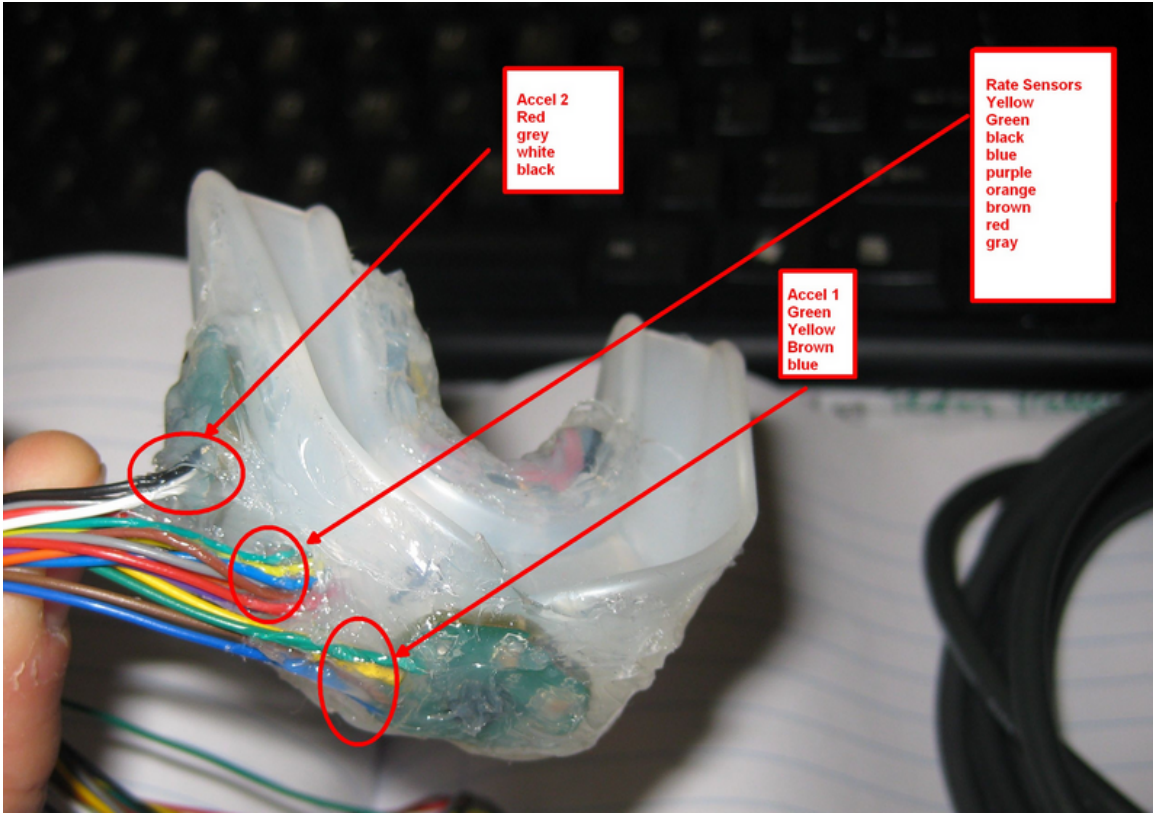
A mouthpiece which contained 3 linear accelerometers and 3 angular rate sensors was provided by Mr. Larry Chickola, Chief Corporate Engineer of Six Flags Theme Parks. This mouthpiece is the same technology as the biteplate used in the study by Pfister. [4] The previous mouthpiece was that of a biteplate; three linear accelerometers (Crossbow, model CXL25M3, San Jose, CA) and 3 angular rate sensors (Murata, model ENC-03J, Tenjin Nagaokakyoshi, Kyoto, Japan) were mounted onto the biteplate in an orthogonal fashion. The x-axis lies in the anterior-posterior direction, y-axis in the lateral direction, and z-axis in the axial direction. [4]

The current mouthpiece used a sports mouthguard instead of a biteplate, with the three ENC-03M gyroscopic sensors adhered in an orthogonal fashion and the two ADXL321EB accelerometers adhered to the front of the mouthguard. By using a mouthguard instead of a springboard style biteplate, the sensors were located within the mouth of the subject, reducing the chance of vibration occurring outside of the mouth. The sensors were connected to a DATAQ data recorder, which was connected via USB to a netbook computer.

Data was collected via a Windaq recording module, over seven voltage channels. The accelerometers used four channels, X, -Z, -Y, Z with a scale factor of 100 mV/g for the resulting data. The gyroscopic sensors each used one channel, which represented the orthogonal, X, Y, and Z directions. The gyroscopic sensors began at 1.35 V= 0 degrees, with a scale factor of -0.67 mV/deg/s. Data was collected at a rate of 137Hz over the seven channels.



**Figure 2.10** Biteplate mouthpiece and sensor orientations [4]



**Figure 2.11** Sportsguard mouthpiece

## 2.4 Software

Initially software collection was controlled by a Matlab script written by Ascension Technologies, however it was discovered that this software caused a buffering issue where the RAM being filled faster than the data could be transcribed, thereby overwriting itself as it was being collected. To resolve this, a C program was used to record the trakSTAR™ data through USB. The program was set to record the data at least 200 samples/second, but captured it as fast as it could.

Data from the trakSTAR™ was stored in raw form as a .txt file. Matlab was used to convert the data from each sensor into a 7 column array, X, Y, Z, azimuth, elevation, roll, and time. Plots were constructed using the plot function, and the statistics toolbox was used

to pinpoint the minimum and maximum motions experienced by the sensors during the rides.

Analog to digital conversion of the data collected from the mouthpiece was done using the Windaq software provided with the data recorder. The software allowed for the data to be opened as a waveform browser. Once opened as a waveform, the motion which indicated the start of data collection was pinpointed and selected. The software allowed for the data corresponding to the selected waveform to be exported as a raw text file. Further processing of the data would need to be completed in Matlab at a future date.



## CHAPTER 3

### DATA COLLECTION

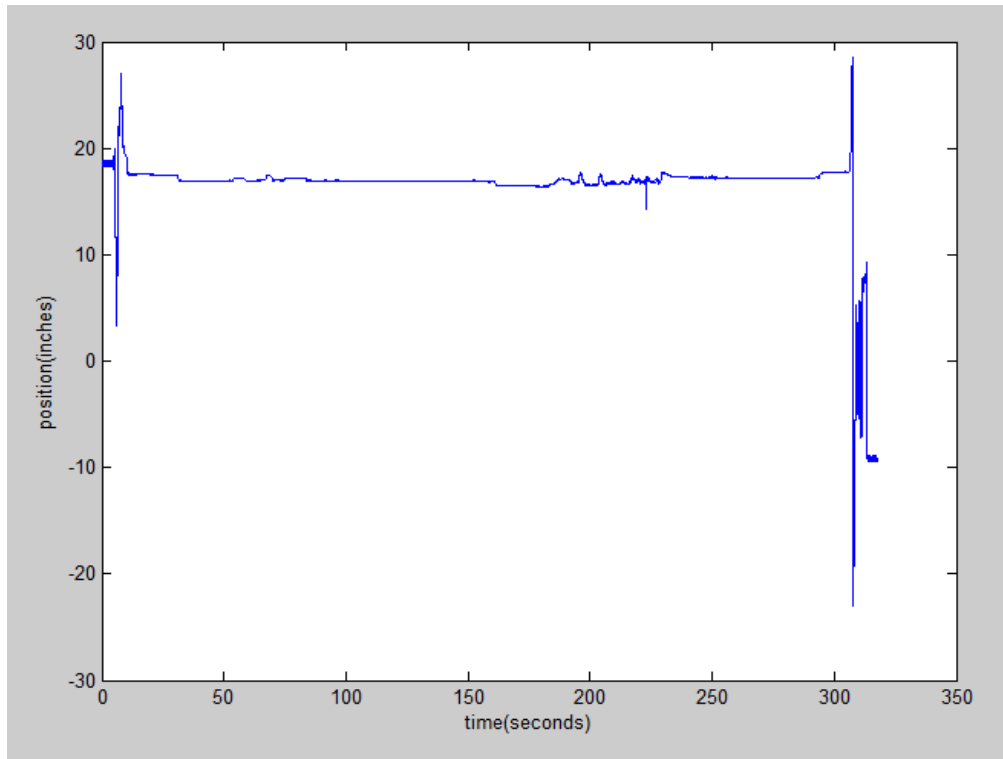
#### 3.1 Verification and Validation

The use of a trakSTAR™ system on a ride brought 2 concerns. The first concern was whether the trakSTAR™ could collect the motion data from the HAMPRE box while both the subject and the transmitter were moving. The second concern was whether the trakSTAR™, which uses electromagnetic fields to track position, could collect data on a roller coaster without experiencing interference.

To test the ability to collect data while moving, testing was conducted in a hallway. The 4 trakSTAR™ sensors were attached to the subject and they were instructed to sit in an office chair. This office chair was attached to a second office chair to the left of it. The trakSTAR™ was activated and the person was pushed up and down the hallway. The HAMPRE was then opened and it was confirmed whether data was still collecting in real time.

To test if roller coaster rides would generate electromagnetic interference, a trakSTAR™ unit, and laptop computer were taken to Six Flags. There the potential rides for the study were tested by placing the transmitter on the ride itself. A ruler was taken out and placed near the transmitter. To indicate whether interference was occurring while on the rides, the sensors were placed around where the subject would be sitting, at distances measured by the ruler. It was verified that no noticeable interference was occurring, as the computer data confirmed the distances marked by the ruler.

To test if the HAMPRE system as a whole was collecting data on the rides, the entire apparatus was subject to a control test run prior to data collection. The trakSTAR sensors were taped at various locations on the box and were sent on the rides without a subject. Data collection was then confirmed via plotting of the raw data in Matlab.



**Figure 3.1** Verification of data collection from a trakSTAR™ sensor on Batman

### **3.2 Subject Selection**

The use of HAMPRE to collect motion data from subjects was given IRB approval by NJIT. The attachment of the trakSTAR™ sensors as well as the use of the mouthpiece was deemed safe. Six Flags also approved the use of their facilities for the study at the Six Flags Great Adventure Park.

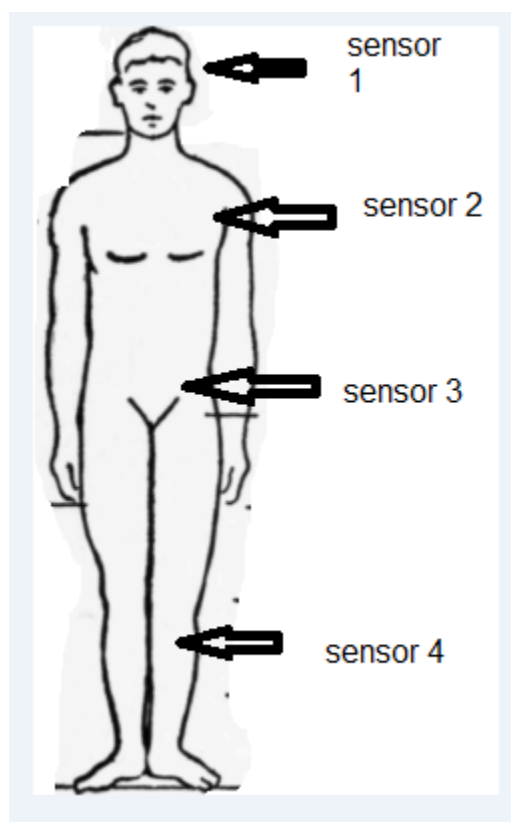
A total of fourteen subjects were selected through NJIT, students responded to advertising for the study placed around the school. A consent form was filled out by each subject for participation in the study. The consent form outlined the procedure that would occur, the exclusion criterion for the study, as well as risks and understanding of confidentiality.

Requirements for exclusion from participation included the following, if the subject does not meet ride height and weight restrictions, the subject has a serious medical condition, is pregnant, has previously sustained traumatic injury, sustained or diagnosed with a concussion, have a disease of the muscles or nervous system, wear an electronic assist device such as a pace maker, has a known condition which causes the subject to lose consciousness, or if the subject takes any medication which could impede measurements taken in the study. The subject was also excluded if they drank alcoholic beverages the night before the study.

### **3.3 Data Collection**

On the day of data collection, 14 subjects were gathered for 3 rides, Batman, Nitro, and Superman. Subjects were initially given an initial participation evaluation questionnaire which ensured their ability to participate on the day of the study. Subjects were given a number, which corresponded to their order for the rest of the day.

Prior to each ride riders were given a baseline questionnaire which assessed their stress/anxiety states as well as their enthusiasm for rides. Subjects were strapped with four sensor holders before riding, at the head, shoulder, waist, and leg. Pre-ride blood pressure readings were collected from the participants. Once sitting in the ride, trakSTAR™ sensors were attached into the holders and a sanitized mouthpiece was given to the subjects. Data collection would be initiated on the trakSTAR™ device as well as the Windaq control for the mouthpiece.



**Figure 3.2** trakSTAR™ sensor placement

Prior to the ride beginning the subject was asked to shake their head back and forth. This shaking created a physical marker on the data for both the trakSTAR™ and the

mouthpiece and would allow for the data from both devices to be synced together during data analysis.

The ride would begin once the platform was clear of all unnecessary personnel. Post-ride blood pressure was taken once the subject had returned along with a post-ride questionnaire which revisited the stress/anxiety state of the participant. Once completed, the sensors were removed and the next subject would be prepped.

To ensure that the trakSTAR™ was successfully collecting data before each ride a test run was conducted, with the 4 motion sensors attached at fixed points to the HAMPRE box, 6, 8, 10, and 12 inches away. The HAMPRE was then sent on the ride and the resulting file was checked to confirm that data was successfully being recorded.

### **3.4 Collection Failures**

Prior to the collection of data on the three roller coasters subjects had been recruited to participate in the study and ride the rides on two prior dates. The first date, already shortened due to inclement weather, was ended early due to a logistical failure where the battery in the HAMPRE was depleted, and the replacement was not available readily. To account for this failure in trials, the procedure was changed to automatically change the battery with a fully charged one at the halfway point of data collection.

Data collected from the trakSTAR™ on the first two collection dates was found to be incomplete after collection was completed. Investigating into this issue resulted in the discovery that the data collection buffer was being filled too quickly, resulting in the data being purged before it could be moved to permanent memory. As a result of this failure,

Matlab control of the trakSTAR™ system was abandoned, and a standalone program provided by Ascension technology was used instead.

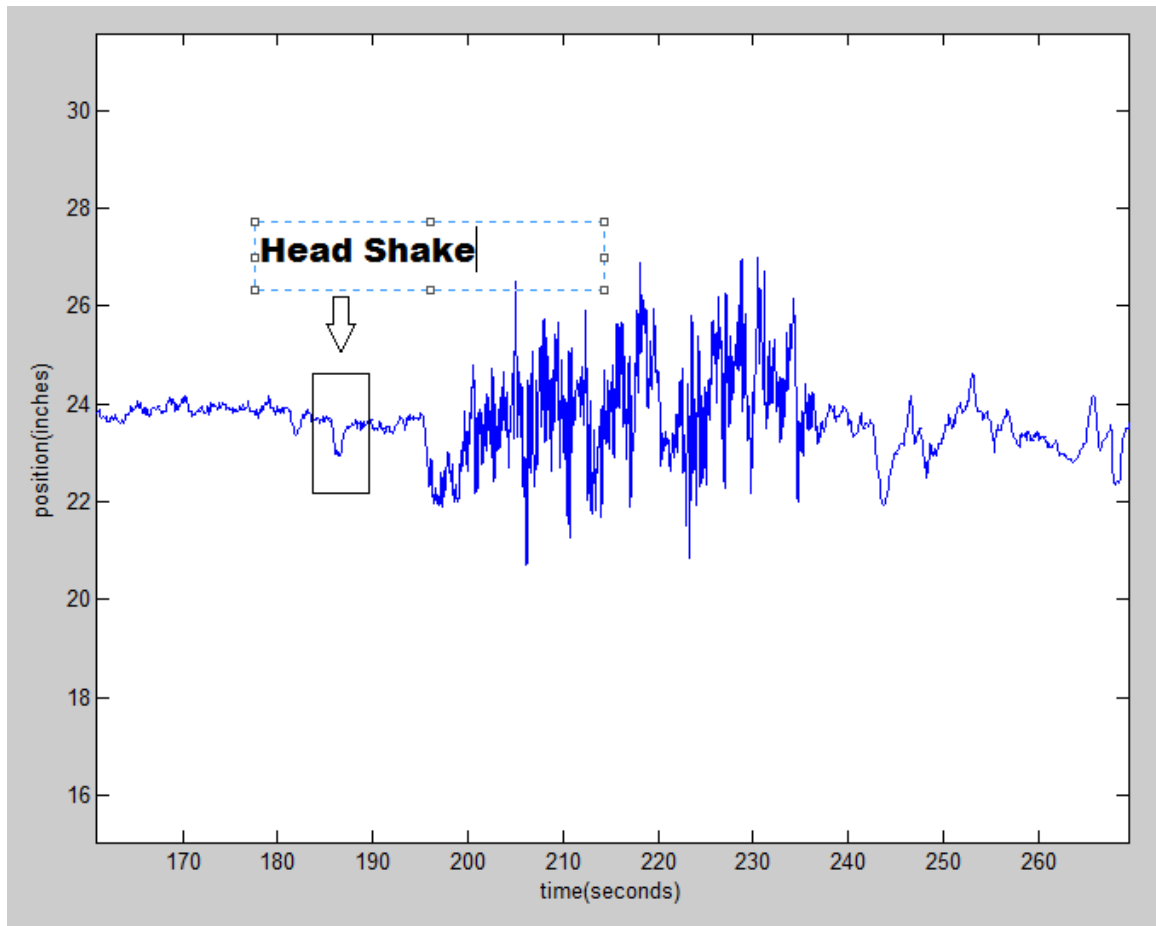
## CHAPTER 4

### RESULTS

#### 4.1 Cropping of Raw Data

Based on the trakSTAR™ test run before each ride it was evident that data from the motion sensors was successfully being recorded. This evidence was based on the size of the files and the locations being reported by the sensors. However it was not evident whether the system, specifically the trakSTAR™ was giving clear data. To confirm that the trakSTAR™ was successfully recording data, the files had to be imported into Matlab and plotted. The data recorded from trakSTAR™ was broken down into 25 different columns, the 6 degrees of motion from each of the 4 sensors (X, Y, Z, Azimuth, Elevation, Roll), as well as a time stamp column. The data from each subject was extracted, and stored in 5 different arrays labeled HEAD<subject#>, SHO<subject#>, HIP<subject#>, LEG<subject#>, and Time<subject#>.

Each trial had to be plotted and examined to view the area of activity which was the actual roller coaster data. The shaking of the head before the ride started created a physical marker which would identify where the area of activity in the data was. The shake of the head was identified by a sharp movement in the head sensor, along the X axis, followed by a steady period. By identifying the shaking motion, the extraneous pre-ride data could be excluded.

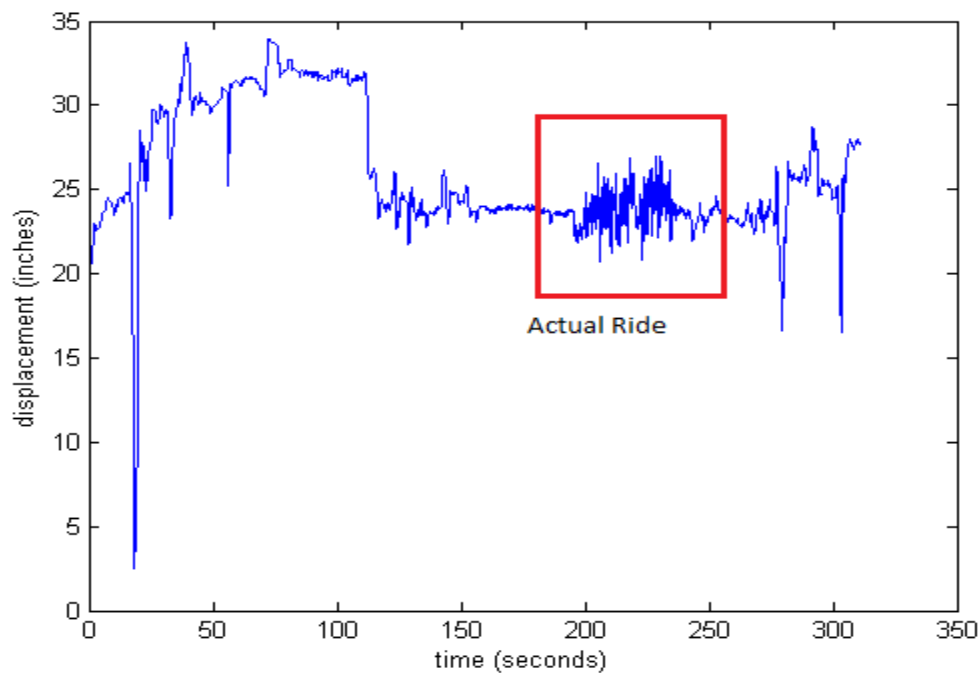


**Figure 4.1** Identification of head shaking physical marker

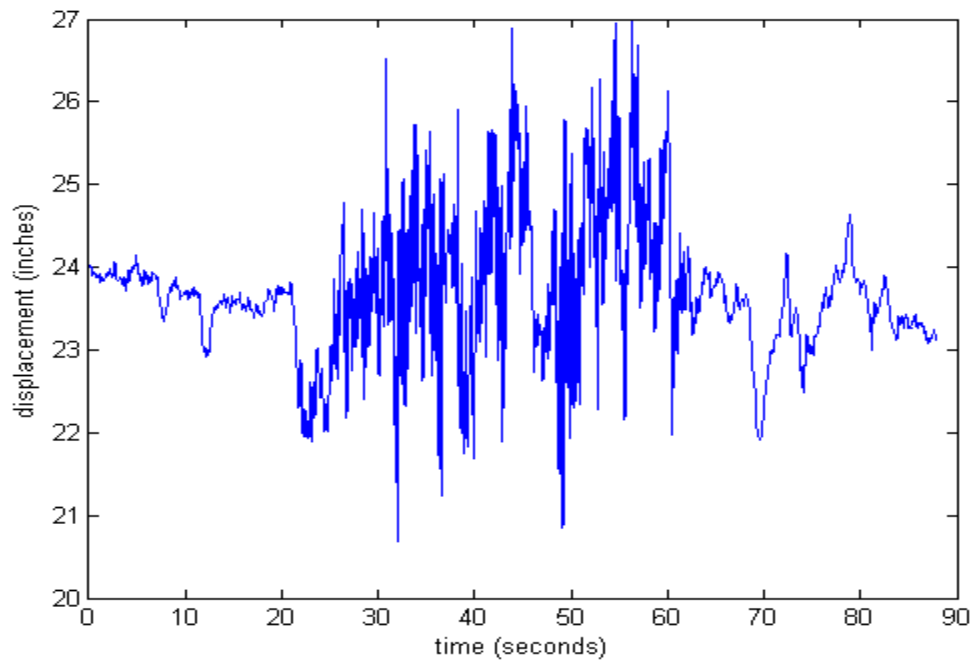
While the ride only encompassed 70 seconds of data, approximately 250-300 seconds of data were collected for each subject. This excess was due to the logistics of data collection, the devices in HAMPRE had to be set to collect data, the whole apparatus had to be secured into the ride, and then the platform of the ride had to be cleared of all non-Six Flags personnel. The excess on the back end of the data was caused by the need to undo the safety harnesses, open the HAMPRE, and then stop collection manually on the laptop.



Figures 4.2 and 4.3 show the raw data and the subsequent trimmed data which was the actual ride itself. Those figures are the motion of one subjects head in the x-direction (left and right) relative to the transmitter.



**Figure 4.2** Ride data trial before trimming



**Figure 4.3** Ride data trial after trimming

After trimming was done on all of the subjects' ride trials, the largest changes in the data were focused on. The changes were large motions in the X and Y directions of the head sensor, which could be observed by seeing the distance they had moved. Change in distance in the x-direction corresponds to the head moving left and right, change in the y-direction corresponded to the head moving forward and back, and change in the z-direction was up and down movement. By looking at the large changes, and the time at which they occurred, features of the roller coaster could be associated with changes in data. For example, the change in distance from the baseline at the beginning of a ride corresponded to the first large drop that the subject experienced.

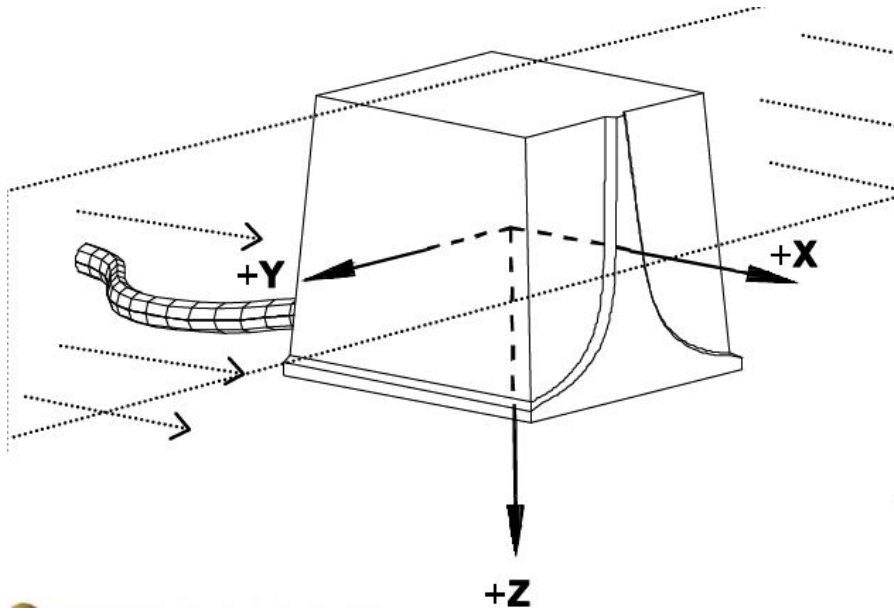
From Batman one subject had data which did not show a discernible area of activity, indicating there was some problem with data collection during the ride for those subjects,

they were subsequently omitted. Four subjects that participated on the Nitro and Superman rides also had indiscernible baseline measures, and ride measures.

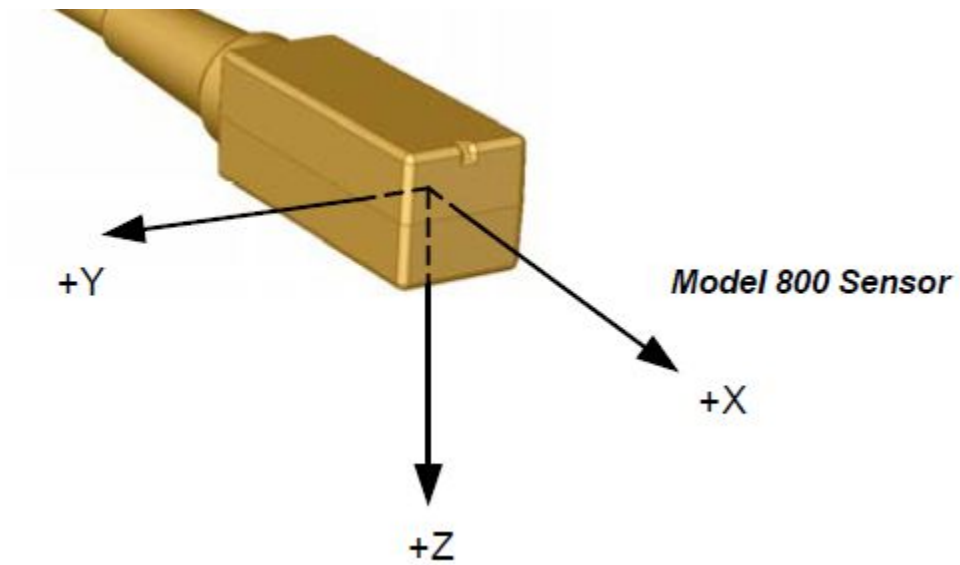
## **4.2 Batman Data**

The data from the trakSTAR™ was the focus of the data analysis, as it was a new source of data which had not been looked at before. The mouthpiece used in this study was applied in the same manner as the previous iteration which had been used in the prior study by Pfister et al, and was provided by the same source, Larry Chickola of Six Flags. [4] Data was successfully recorded via the DATAQ and was saved onto the netbook computer.

When looking at the ride data for Batman it was important to focus on the head motions of the subjects. The subject was held in place by a shoulder and lap restraint, leaving the head as the only sensor with freedom of movement. Data statistics were performed using the Matlab statistics tools built into the code, this produced the mean, maximum, and minimum values in inches for each subject. The data in the X direction is the movement of the head left and right, relative to the transmitter it is the head moving closer or farther away. The mean received was the equivalent of the riders starting position, based. The maximum distance the sensor was away from the transmitter, is the equivalent of the head moving to the right, away from the transmitter, and minimum head motions corresponded to the head moving left, towards the transmitter. By finding the net difference between the max head motion and the minimum head motion, the total distance range of head motions to the right and left became discernible



**Figure 4.4** trakSTAR™ transmitter orientation [5]



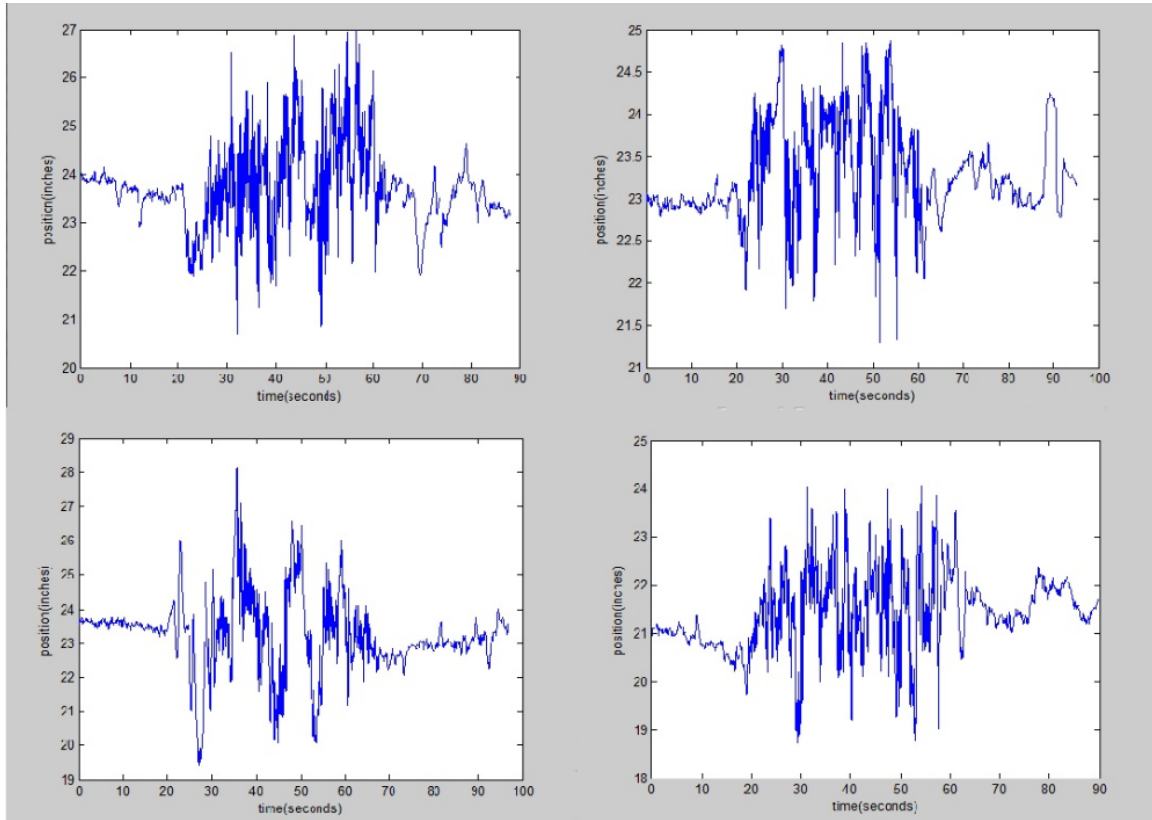
**Figure 4.5** trakSTAR™ sensor orientation [5]

Subject	Height (inches)	Weight (lbs.)	MEAN (inches)	MAX (inches)	MIN (inches)	TOTAL RANGE OF MOTION (inches)
1	72	240	23.69	26.98	20.69	6.29
2	73	159	21.49	24.64	18.55	6.09
3	69	145	23.29	24.87	21.3	3.57
4	72	160	23.24	28.13	18.42	9.71
5	72	211	22.32	25.74	19.92	5.82
6	71	210	21.42	24.06	18.73	5.33
7	64	120	22.66	24.73	20.43	4.3
8	70	140	21.65	26.49	18.16	8.33
9	74	294	24.16	28.24	20.45	7.79
11	60	174	24.1	25.67	22.35	3.32
12	64	170	22.44	24.69	20.81	3.88
13	65	140	25.43	28.3	23.5	4.8
14	60	105	23.95	25.84	22.83	3.01
AVERAGES	68	174	23.06	26.03	20.47	5.56
STD	4.9	52	1.20	1.48	1.72	2.067

**Table 4.1** Batman data: sensor displacement relative to transmitter along the X axis

The movement in the x-direction in the x direction showed an average net range of motion of 5.56 inches. The mean of head placement was at 23.06 inches away from the transmitter, while the average maximum was 26.03 inches away. The maximum distance from the transmitter happened on right handed banking turns where the head would move away from the HAMPRE. The minimum, or the smallest distance away from the transmitter, occurred during left handed turns where the head would move towards the HAMPRE. The

graphs of movement in the x direction showed a pattern of oscillation between left and right, this can be attributed to the large amount of corkscrew like features, and turns in the ride.



**Figure 4.6** Pattern of oscillations along the x axis.

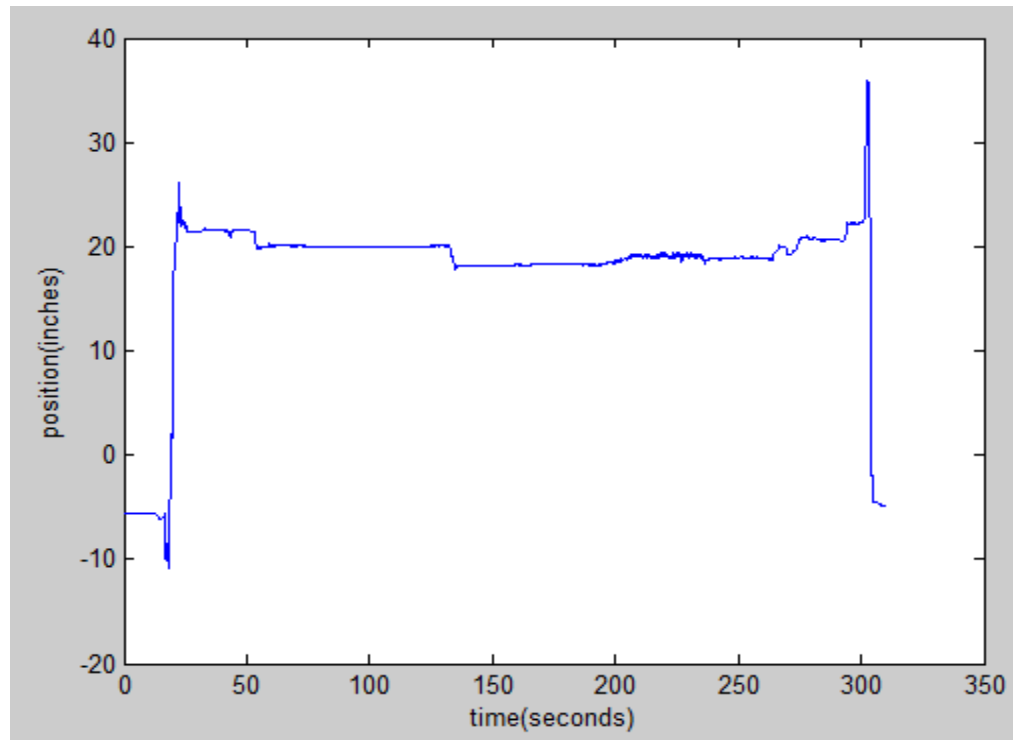
Movement of the sensor along the y-axis corresponds to the heads forward and backwards movement to the placement of the sensor relative to the transmitter. Based on the orientation of the transmitter axis shown in Figure 4.3, the head of the subject began with the sensor on the side of the  $-y$  axis. The largest forward and backward movements of the head occurred on the large beginning drop and the subsequent loop that took place on the ride. Due to the large presence of corkscrew elements on the Batman ride, large oscillations weren't present in the forward and backwards data, with large dips being most prevalent.

Subject	Height (inches)	Weight (lbs.)	MEAN (inches)	MAX (inches)	MIN (inches)	TOTAL RANGE OF MOTION (inches)
1	72	240	-2.646	1.96	-5.326	7.286
2	73	159	-7.233	-3.37	-13.77	10.4
3	69	145	-1.623	-0.813	-6.882	6.069
4	72	160	-7.703	-5.102	-15.32	10.218
5	72	211	-8.67	-3.234	-11.12	7.886
6	71	210	-6.419	-1.851	-8.713	6.862
7	64	120	-2.665	-0.47	-5.168	4.698
8	70	140	-6.266	-1.34	-7.4	6.06
9	74	294	-5.436	5.256	-10.68	15.936
11	60	174	-3.353	0.07	-5.313	5.383
12	64	170	-0.9735	2.588	-3.819	6.407
13	65	140	-2.224	-0.022	-4.742	4.72
14	60	105	-4.46	-2.158	-8.675	6.517
AVERAGES	68	174	-4.59	-0.65	-8.22	7.57
STD	4.9	52	2.53	2.65	3.61	3.08

**Table 4.2** Batman data: sensor displacement relative to transmitter along the Y axis

The movement in the y-direction had a larger variation in their starting positions at the beginning of the rides. This resulted in a large variation in the total range of motion of the head moving backward and forward. One subjects head moved a total of 15.94 inches forward and backward throughout the ride, while the smallest range of motion was 4.70 inches. While the standard deviation for total range of motion in the x direction was 2 inches, the standard deviation for movement in the y direction was 3.08 inches.

Due to the harness system on the batman ride, riders were held in place from above, keeping them firmly in their seats for the duration of the ride. Unlike other coasters, i.e. Nitro, the rider would not be able to experience distinct movement along the z-axis.



**Figure 4.7** Movement in the Z-direction

Data which can be interpreted are produced when looking at the Batman coaster. However, these data are for head motions, since the hip and shoulder sensors are held in place by the ride harness, it is important to look at another roller coaster to confirm that data from other sensors is coming in clearly.

### 4.3 Nitro Data

The Nitro roller-coaster is different from Batman because it uses high speeds and hills, rather than loops and corkscrews, to create the “thrill-ride” experience. “Nitro begins its journey



with a 233-foot lift hill. After cresting the top, the train drops 215 feet at 68 degrees, reaching its top speed of 80 mph. A second lift hill — 189 feet — follows, along with a dive down through a 161-foot hill. From here, Nitro enters into a hammerhead turn, a tight U-turn to the right. Soaring over another camelback hill, it enters an S-curve and 540-degree helix, followed by three camelback hills, before its return to the station.” [7]

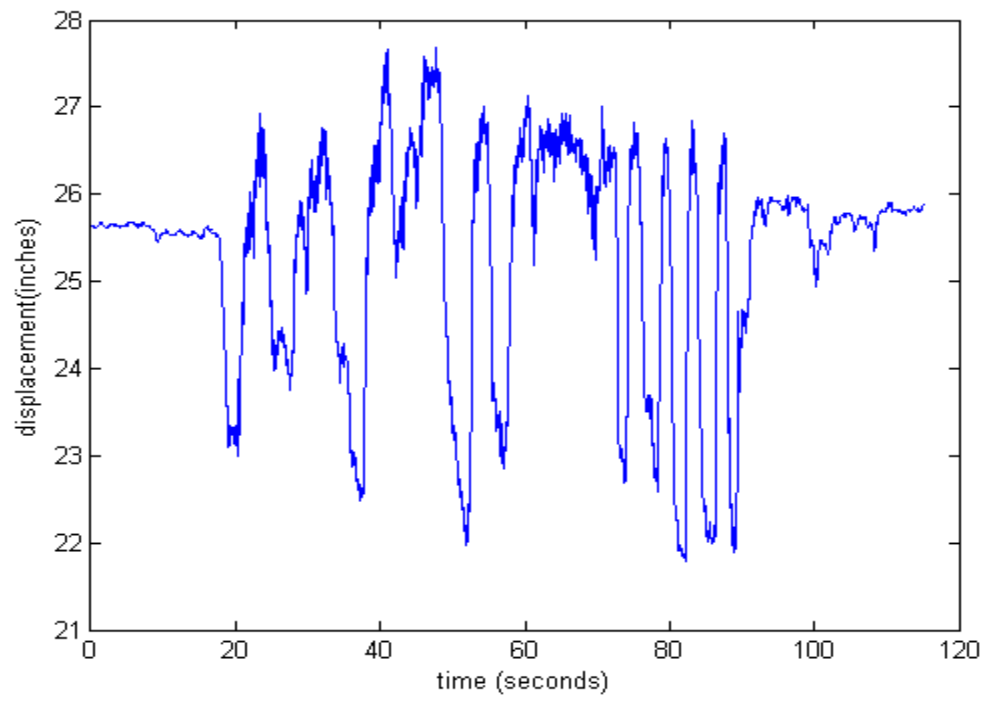
To confirm that the trakSTAR™ was capturing motions at the hip sensor, the change in the z-direction on the hip sensor was observed. Because of the 2 lift hills and subsequent camelback hills, the change in the z-direction at the hip indicated whether or not the subject experienced “lift” out of the seat.

Subject	Height (inches)	Weight (lbs.)	MEAN (inches)	MAX (inches)	MIN (inches)	TOTAL RANGE OF MOTION (inches)
1	70	140	25.33	27.68	21.79	5.89
2	73	159	25.79	28.98	20.93	8.05
3	69	145	24.63	26.57	22.86	3.71
4	72	160	26.78	28.88	21.63	7.25
5	72	211	21.73	23.87	20.81	3.06
6	71	210	25.48	27.11	23.53	3.58
10	60	174	23.5	24.73	21.96	2.77
11	64	170	21.66	23.07	19.06	4.01
12	65	140	21.22	22.15	19.02	3.13
13	74	294	24.4	25.23	23.49	1.74
14	72	240	27.08	27.83	25.39	2.44
AVERAGES	69	186	24.33	26.01	21.86	4.15
STD	4.4	48.5	2.06	2.35	1.92	2.03

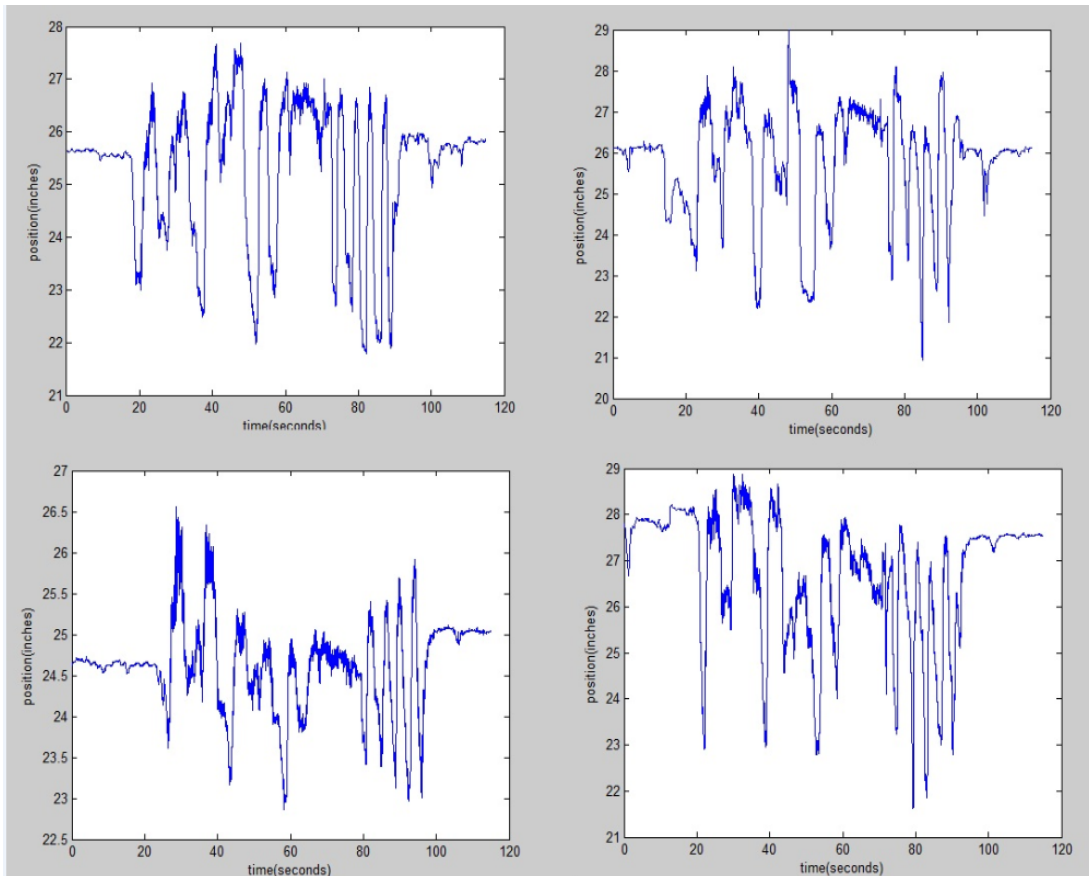
**Table 4.3** Nitro Data: Hip Sensor movement along the z-axis

The +Z plane of the transmitter projects out of the bottom of the transmitter, as a result when a subject experienced lift out of the seat, the hip sensor moved closer to the seat.

The average position of the hip sensor was 24.33 inches away from the transmitter, and the average maximum lift was 21.86 inches, a noticeable change. On the larger hills the sensor dropped below the starting position of the sensor. The sensor moved further away from the HAMPRE to an average of 26 inches, or 1.68 inches away from the average starting position.



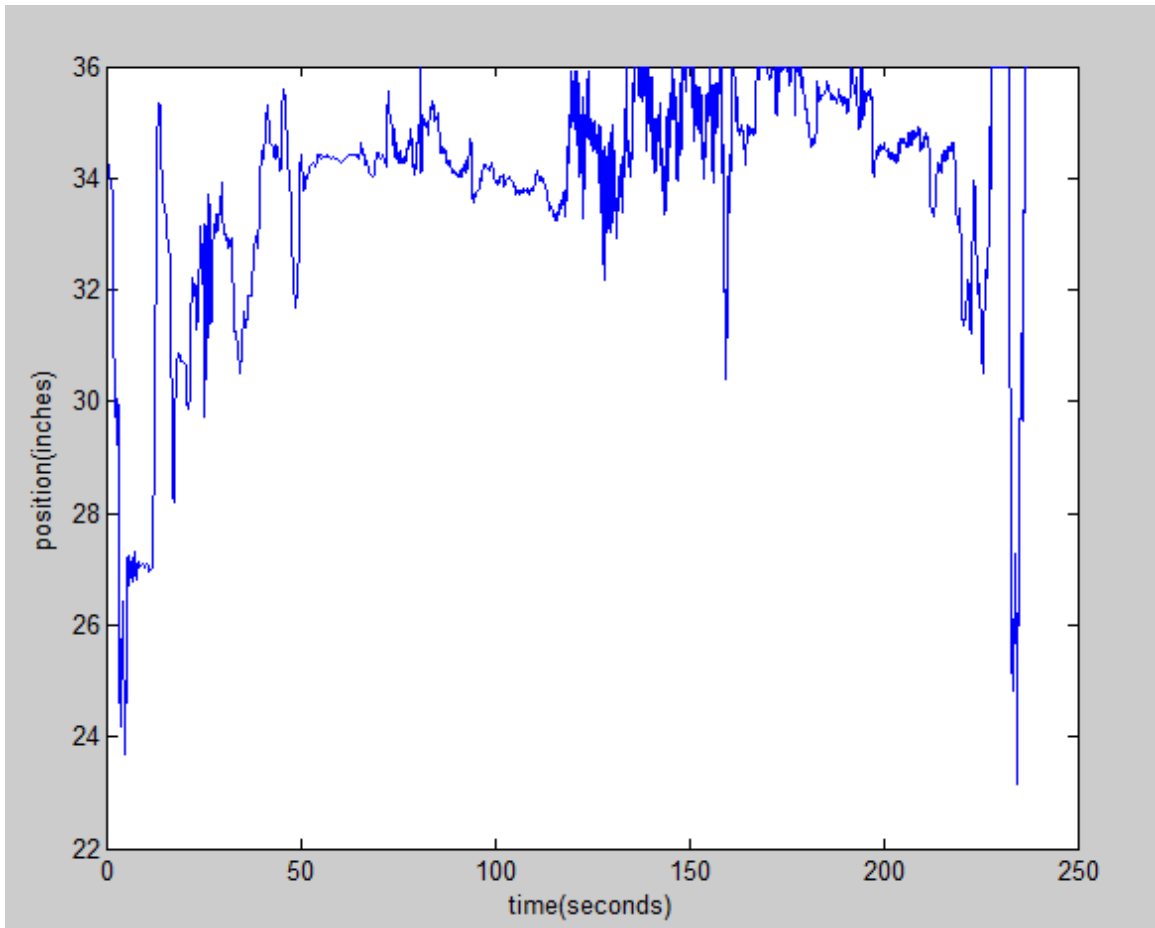
**Figure 4.8** Example of Nitro subject data demonstrating lift from seat



**Figure 4.9** Pattern of lift out of seat on Nitro from 4 subjects

#### 4.4 Superman Data

The data which was collected from the Superman trials did not produce clear, discernible data. When observing motions experienced by riders, no distinct ride features were seen through the trakSTAR™ data; figure 4.10 shows an example of this, in the head motions of a subject on Superman. The head is shown to be constantly moving, even though there is a long pause between the beginning of data collection and the physical start of the ride.



**Figure 4.10** Example of Superman ride data

## **CHAPTER 5**

### **Conclusions and Future Work**

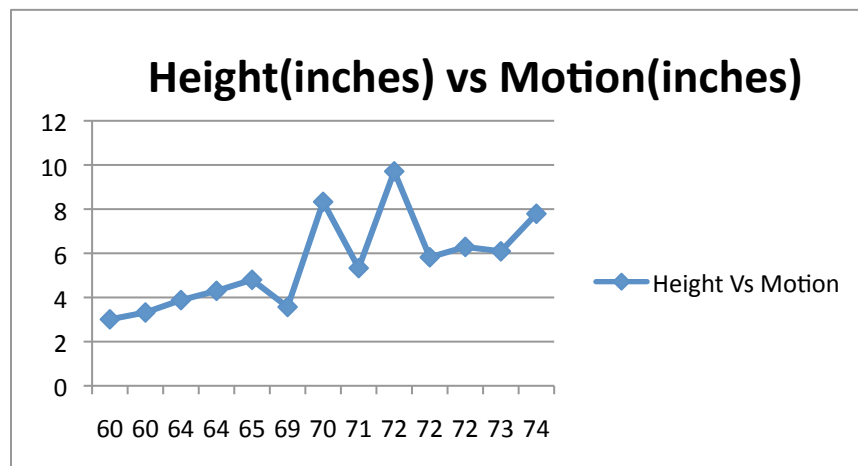
#### **5.1 Conclusions**

After confirming that the motions experienced on the rides were identifiable motions in the trakSTAR™ data, it can be concluded that the HAMPRE system successfully collected and captured the riders' motions on roller coaster rides. Batman and Nitro are both roller coasters with very distinct features which produced distinct changes, large oscillations along the x-axis for Batman, and large movements along the z-axis for Nitro.

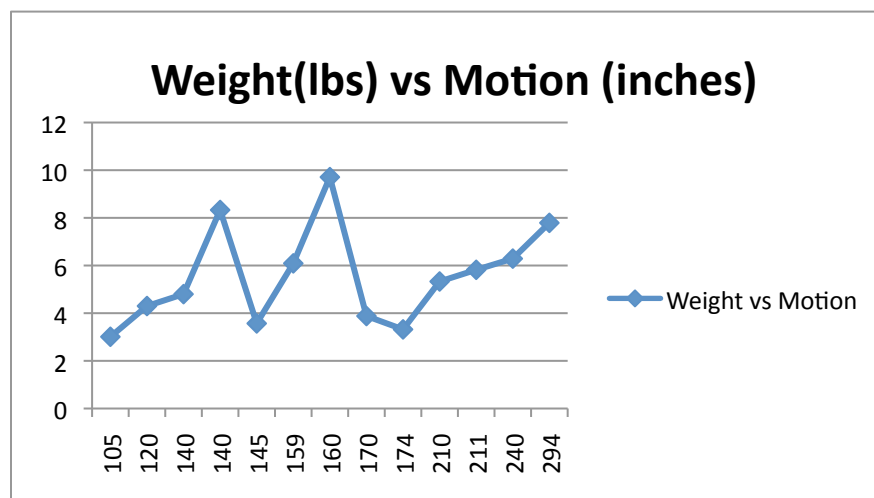
It can also be concluded that there are still flaws in the system. The attachment of the sensors along the waist was done using a plastic sensor holder attached to a regular leather belt. The belt was used by all subjects regardless of their size, resulting in a snugger fit on larger girth subjects and a looser fit on thinner subjects. Because of the looseness of the belt, movement independent from the body could also have been registering during data collection. Based on this I'd recommend investigating if this finding has any effect on data collection.

Because the subjects were not the same proportions, there was a large difference in the starting placements for the sensors. As a result there were also large differences in the range of motion between the riders. A theory could be made that the girth of the rider can translate into a smaller range of motion, due to the further restrictions posed by the safety harness.

Another theory that these results pose is that riders with larger heights experience a smaller range of motion on rides with a torso safety harness. Because of the smaller amount of space in the shoulder region of the safety harness, the taller riders are held more firmly in place and experience less movement as they are more confined. Figure 5.1 and 5.2 show height and weight versus motion data. These graphs indicate that there isn't a conclusive correlation; however it is something to be further explored.



**Figure 5.1** Height vs. Motion on Batman



**Figure 5.2** Weight vs. Motion on Batman

## 5.2 Future Work

The data that was collected at Six Flags is much greater than the set of data that was analyzed for this thesis project. Because it is confirmed that the HAMPRE can collect rider motion data using the trakSTAR™, the data from the trakSTAR™ needs to be compared to the data received from the mouthpiece provided by Mr. Chickola, as well as the BioHarness™ provided by Michael Bergen. The pre-ride and post-ride surveys which the riders filled out need to be evaluated, to see if they correlate to a change in the physiology of the subjects.

The data from the Superman: Ultimate Flight roller coaster needs to be further explored. Because the rider is put into a very unique position where they are initially parallel to the ground, have both torso and lap restraints, and force riders to crane their necks forward to look ahead, it would have been difficult to prove that the trakSTAR™ was working properly based on the motions presented in that ride. By concluding that the trakSTAR™ was producing usable data, it would be important to see if the unique position created any unique motions that were not seen in the more traditional coasters.

## 5.3 Improvements

If more data are to be collected from other roller coasters in the future, the procedure from which data was collected should be improved. Because of the quickness and confusion at the platforms the trakSTAR™ sensor was rotated to the wrong orientation in some cases. This led to confusion during analysis. Another improvement that could be made is for the trakSTAR™ to be activated at the very last possible moment, reducing the amount of data trimming that needs to occur to isolate the actual ride. Sensor placement can also be improved, by placing the sensors at fairly uniform locations on the riders. The one size fits



all equipment which was used to fasten the sensors to the riders resulted in a variation in the sensor location.

The addition of a camera from the riders perspective could aid in improving the capture of rider motions, as we would have a direct visualization of the subjects perspective, allowing for a unique ride profile could be created for each subject, instead of using videos of other rides to identify ride features through the motion data.

## APPENDIX A

### BATMAN DATA LOADING SCRIPT

```
%This script loads the Raw six flags data from Batman the Ride into an
%array labeled M. M is then trimmed at specific time points, and split
%into 4 different arrays representing each sensor HEAD, SHO, HIP, LEG, and
a 5th Array

%representing the timestamp, TIME. Plots are made from this data, and
data

%statistics are performed within graphs.

Data1=importdata('Batmansubject1',' ',2); M1=Data1.data;

M1=M1(1.023E5:1.543E5,1:29);

HEAD1=M1(:,2:7);

SHO1=M1(:,9:14);

HIP1=M1(:,16:21);

LEG1=M1(:,23:28);

TIME1=M1(:,29);

TIME1=TIME1-TIME1(1,1);

TIME1=transpose(TIME1);
```

## APPENDIX B

### NITRO LOADING SCRIPT

```
%This script loads the raw data from the ride NITRO, it saves the data into
```

```
%an array M which is then trimmed at the area where the ride is occurring.
```

```
%The data is split into 5 arrays one for each sensor and time. 3 subjects,
```

```
%7,8,9 were not loading.
```

```
Data1=importdata('Nitrosubject1',' ',2); M1=Data1.data;
```

```
M1=M1(78045:147260,1:29);
```

```
HEAD1=M1(:,2:7);
```

```
SHO1=M1(:,9:14);
```

```
HIP1=M1(:,16:21);
```

```
LEG1=M1(:,23:28);
```

```
TIME1=M1(:,29);
```

```
TIME1=TIME1-TIME1(1,1);
```

```
TIME1=transpose(TIME1);
```

## REFERENCES

1. Rutsch, Sebastian, Wolf-Dirk Niesen, Stephan Meckel, and Matthias Reinhard. "Roller coaster-associated subarachnoid hemorrhage-report of 2 cases." *Journal of Neurological Sciences*. 315. (2012): 164-166. Print.
2. Braksick, Robert, and David Roberts. "Amusement Park Injuries and Deaths." *Annals of Emergency Medicine*. 39.1 (2002): 65-72. Print.
3. Kuschyk, Juergen, Dariusch Haght, et al. "Cardiovascular Response to a Modern Roller Coaster Ride." *Journal of the American Medical Association*. 298.7 (2007): 739-741. Print.
4. Pfister, Bryan, Larry Chickola, and Douglas Smith. "Head Motions While Riding Roller Coasters: Implications for Brain Injury." *American Journal of Forensic Medical Pathology*. 30.4 (2009): 339-345. Print
5. *Ascension Technology Corporation, trakSTAR™*;  
<http://www.ascension-tech.com/medical/pdf/TrakSTAR™SpecSheet.pdf>, 2006,  
accessed May 2011
6. *Zephyr Technology, BioHarness™*  
<http://www.zephyr-technology.com/wp-content/uploads/2010/12/BioHarness™-BT-Data-Sheet-2010-11-18.pdf>, 2011, accessed May 2011
7. *Six Flags Great Adventure, Nitro Ride Page*;  
<http://www.sixflags.com/greatAdventure/rides/Nitro.aspx>, 2001, accessed October 2011
8. *Subarachnoid Hemorrhage, PubMed*  
<http://www.ncbi.nlm.nih.gov/pubmedhealth/PMH0001720/>, 2011, accessed July 2012